

Elena Costa * Lilli Doniselli * Alba Taino

RISORSE
E STRUMENTI
PER L'INSEGNANTE

AREA LINGUISTICA

**Italiano
per stranieri
1° livello**

Il bambino straniero in classe

La presenza di alunni stranieri nelle diverse classi della Scuola Primaria è una realtà sempre più diffusa. Tuttavia i bambini che giungono nel nostro Paese portano con sé bisogni particolari cui la scuola non sempre è in grado di rispondere.

Questo testo si rivolge a tutti gli insegnanti che si trovano ad affrontare l'inserimento nella propria classe di un bambino straniero con nessuna o scarsa conoscenza della lingua italiana.

L'obiettivo è quello di fornire ai piccoli allievi uno strumento per affrontare in modo autonomo le prime difficoltà dell'apprendimento della lingua e agli insegnanti alcuni suggerimenti per vivere l'arrivo di un nuovo alunno come una risorsa per la propria classe, superando le difficoltà legate all'adeguamento dei ritmi di apprendimento e di insegnamento.

Risorsa o problema?

Il bambino che entra nella scuola provenendo da un altro Paese porta con sé un bagaglio di conoscenze, di abitudini, di colori, di storie differenti, che possono trasformare la classe in modo davvero speciale.

La conoscenza diretta di abitudini e di luoghi sconosciuti che avviene attraverso il contatto diretto con il nuovo compagno può essere per i bambini della classe un forte stimolo per allargare i propri orizzonti e per imparare cose nuove.

La scuola può diventare realmente un luogo in cui la presenza di culture diverse sia un'occasione di arricchimento per tutti.

Integrazione o cancellazione di identità?

Ogni insegnante sa con chiarezza che ciascun bambino va considerato nella sua interezza e non solo come scolaro.

Ogni bambino porta in classe il suo vissuto, la sua situazione familiare, le sue gioie e le sue paure e noi, nel nostro quotidiano operare, dobbiamo tenere conto di queste condizioni se vogliamo ottenere un proficuo apprendimento. Con ancora più partecipazione vanno perciò ascoltate le storie di chi ha maggiori difficoltà perché si trova in un luogo di cui non capisce né la lingua né le abitudini.

Come procedere?

L'insegnamento della lingua italiana agli allievi stranieri deve basarsi essenzialmente su un lavoro orale. Le schede operative di questa Monografia indicano il percorso da seguire, ma devono essere necessariamente integrate da numerose esercitazioni orali.

Prima di procedere, dovremo rilevare, attraverso un'attenta osservazione del bambino, sia le competenze linguistiche sia i comportamenti relazionali.

È importante che il bambino straniero trovi in classe un clima sereno che lo accolga tenendo conto delle sue peculiarità. I compagni sono una grande risorsa perché, attraverso le esperienze quotidiane, aiutano il bambino a integrarsi nella classe.

L'apprendimento della lingua

Gli alunni stranieri che frequentano le scuole italiane sono più di quattrocentomila e il numero è sicuramente destinato ad aumentare. Si pensi che solo vent'anni fa erano poco più di seimila.

I bambini provengono da tutte le parti del mondo: sono stati censiti alunni provenienti da 187 paesi (gli Stati mondiali sono 194). La maggior parte arriva dall'Albania, dal Marocco, dalla Cina, dalla Romania, dalla ex Jugoslavia, dall'Ecuador.

L'apprendimento della lingua può essere facilitato da un clima accogliente che invita alla comunicazione. I bambini, generalmente, apprendono la lingua, semplicemente sentendola parlare. È però necessario ripetere loro i vocaboli e le consegne.

È bene rivolgersi al bambino con frasi semplici e brevi. Può esser utile procurarsi un vocabolario della lingua d'origine del bambino per affrontare le prime difficoltà della comunicazione.

L'apprendimento della letto-scrittura

Per l'apprendimento della letto-scrittura è possibile utilizzare o un solo carattere (stampato maiuscolo) o tutti e tre i caratteri (stampato maiuscolo e minuscolo, corsivo)

Il bambino straniero, generalmente, non presenta difficoltà nella manualità: per questo non è necessario presentare solo lo stampato maiuscolo.

Il bambino è in grado di usare anche il corsivo, carattere che, in genere, viene utilizzato dagli altri compagni della classe.

Verso l'autonomia

Le schede presenti in questa Monografia sono strutturate in modo tale che il bambino possa lavorare autonomamente, soprattutto quando noi dovremo volgere la nostra attenzione all'intero gruppo classe.

È però importante cogliere tutte le occasioni possibili per invitare il bambino ad esprimersi e a provare a pronunciare parole nuove.

Osservare e valutare

Nel volume sono presenti:

- una griglia per l'osservazione dei comportamenti e delle conoscenze del bambino al momento dell'inserimento nella classe;
- una griglia per rilevare gli apprendimenti acquisiti al termine del periodo di inserimento.

La normativa

Le circolari ministeriali relative alle iscrizioni alle scuole di ogni ordine e grado che vengono emanate ogni anno regolano anche le iscrizioni degli alunni stranieri.

I principi fondanti sono contenuti anche nel Decreto del Presidente della Repubblica 31 agosto 1999, n. 394, art. 45, nel Decreto Ministero dell'Interno, 23 aprile 2007, nella legge n. 40 del 6.03.1998, nella CM 2 dell'8 gennaio 2010.

Riportiamo alcuni stralci di questi documenti che possono essere utili per individuare le modalità dell'inserimento del bambino straniero.

“I minori stranieri presenti sul territorio sono soggetti all’obbligo scolastico.

L’effettività del diritto allo studio è garantita dallo Stato... anche mediante l’attivazione di appositi corsi e iniziative per l’apprendimento della lingua italiana.

La comunità scolastica accoglie le differenze linguistiche e culturali come valore... promuove e favorisce iniziative volte all’accoglienza, alla tutela della cultura e della lingua d’origine...” (Legge 40, art. 36)

“I bambini e i ragazzi hanno il diritto e il dovere di frequentare la scuola dell’obbligo, per inserirsi a parità di diritti nella società e divenirne soggetti attivi. È dovere di ogni genitore, italiano o straniero, sostenere i figli negli studi, in primo luogo iscrivendoli alla scuola dell’obbligo, che inizia con la Scuola Primaria fino ai 16 anni” (Decreto Ministero dell’Interno, 23 aprile 2007).

“In via ordinaria gli alunni con cittadinanza non italiana soggetti all’obbligo di istruzione sono iscritti d’ufficio alla classe corrispondente all’età anagrafica. I collegi dei docenti possono definire, comunque, le modalità generali dell’assegnazione dell’alunno straniero alla classe inferiore o superiore a quella corrispondente all’età, tenendo conto, come espressamente previsto dall’art. 45, comma 2 del DPR n. 394/1999, dei criteri di seguito riportati:

- a) ordinamento scolastico del Paese di provenienza;
- b) accertamento delle competenze, abilità e livelli di preparazione posseduti;
- c) corso di studi eventualmente seguito;
- d) titolo di studio eventualmente posseduto, accompagnato da traduzione in lingua italiana.

...I collegi dei docenti possono valutare la possibilità che l’assegnazione definitiva alla classe sia preceduta da una fase di alfabetizzazione strumentale e di conoscenza linguistica anche all’interno di specifici gruppi temporanei di apprendimento, finalizzata a favorire un efficace e produttivo inserimento, utilizzando le eventuali ulteriori disponibilità dell’organico di istituto.

Infine, con riferimento alle iscrizioni degli alunni con cittadinanza straniera, effettuate in corso d’anno... si raccomanda l’adozione di particolari forme di accoglienza che possano facilitare, fin dai primi contatti con l’istituzione scolastica, un’efficace azione di integrazione. (Circolare n. 4 prot. n. 381 – 15 gennaio 2009).

Programmazione

<p>ASCOLTARE E COMUNICARE</p>	<ul style="list-style-type: none"> • Ascoltare e comprendere semplici messaggi orali. • Rispondere ai saluti. • Comprendere consegne e indicazioni relative alle attività scolastiche. • Comprendere e rispondere a inviti. • Parlare con pronuncia comprensibile. • Usare vocaboli ed espressioni di uso frequente. • Denominare cose, persone, animali. • Costruire campi lessicali con nomi, verbi, aggettivi. • Chiedere e dare informazioni <ul style="list-style-type: none"> – su se stessi; – sull’ambiente della scuola; – sull’ambiente familiare; – sulle qualità. • Descrivere oggetti, persone e ambienti, anche in relazione alla collocazione nello spazio. • Esprimere i propri bisogni. • Esprimere condizioni soggettive. • Esprimere stati d’animo. • Raccontare fatti relativi all’esperienza personale.
<p>LEGGERE E COMPRENDERE</p>	<ul style="list-style-type: none"> • Possedere la corrispondenza grafema/fonema. • Leggere i digrammi e i trigrammi più semplici. • Leggere e comprendere parole. • Leggere e comprendere semplici frasi. • Associare la parola all’immagine.
<p>SCRIVERE</p>	<ul style="list-style-type: none"> • Conoscere le vocali. • Conoscere le consonanti. • Riprodurre le sillabe. • Scrivere semplici parole. • Scrivere brevi didascalie relative a immagini conosciute. • Scrivere liste relative a campi lessicali noti.

Griglia di osservazione iniziale

Alunno: _____			
	Sì	No	In parte
COMPORAMENTO			
Interagisce solo con gli adulti.			
Interagisce solo con i compagni.			
Entra in relazione nel rapporto a due.			
Comunica attraverso gesti.			
Gioca solo con alcuni compagni.			
Gioca con tutti i compagni.			
Ha un atteggiamento di rifiuto nei confronti della scuola.			
Parla poco, ma cerca di partecipare alle attività.			
Durante le attività si distrae.			
Durante le attività è attento.			
Ha atteggiamenti di sfida.			
È collaborativo.			
È disponibile a raccontare ai compagni le proprie esperienze.			
CONOSCENZA DELLA LINGUA			
Comprende alcune parole.			
Comprende semplici consegne.			
Conosce alcune parole della lingua italiana.			
È capace di formulare una semplice frase.			
Distingue alcune lettere dell'alfabeto.			
Si orienta nel foglio.			
È in grado di copiare segni e simboli.			

Osservazioni:

L'accoglienza

Il bambino straniero che giunge in classe senza alcuna conoscenza della lingua italiana si ritrova in un ambiente che spesso sente ostile.

Come un bambino sordo, non riuscendo a capire che cosa viene detto dagli altri, costruisce dentro di sé una realtà personale, spesso popolata da "fantasmi".

Potremo dare visibilità alla diversità e alla ricchezza linguistica attraverso cartelli di "benvenuto" nelle diverse lingue (cinese: *Huānyíng nín!* – 欢迎您!; spagnolo: ¡Bienvenido!; rumeno: *Bine ai venit!*; russo: *Dobro pozhalovat'!* – Добро пожаловать!; arabo: *Ahlan ua sahan!* – أهلاً وسهلاً!; albanese: *Mirë se vjen;* inglese: *Welcome!*; francese: *Bienvenue!*; portoghese: *bem-vindo;* indiano: *Āpakā svāgata hai!* – आपका स्वागत है!; swahili: *Karibu!*), scrivendo i nomi degli alunni stranieri nella lingua d'origine, scrivendo i nomi degli oggetti della classe in italiano e nella lingua d'origine del bambino, insegnando canzoni e giochi di altri Paesi, raccontando fiabe del Paese d'origine del bambino straniero.

È molto importante la fase dell'accoglienza: il bambino deve sentirsi benvenuto.

Per questo motivo la prima parte di questo testo è proprio dedicata all'accoglienza, che avrà come scopo principale quello di far sentire il bambino parte di un gruppo in cui può raccontare se stesso e le proprie esperienze. Le prime schede lo invitano a parlare del suo vissuto.

È importante che tutta la classe sia coinvolta nell'accoglienza al nuovo venuto. Molte schede, infatti, possono essere completate dal bambino con l'aiuto di un compagno.

Per aumentare il coinvolgimento della classe, sono state predisposte le schede delle pagine 14-15-16 (*I miei compagni*).

Chiederemo ad ogni bambino della classe di fare un piccolo disegno di se stesso e di completare la frase con il proprio nome. Il bambino straniero copierà sulla riga vuota di ogni riquadro solo il nome del compagno. Su un cartellone o sul quaderno personale, poi, potrà copiare tutti i nomi dei propri compagni, suddividendoli tra maschi e femmine.

Per insegnare al bambino straniero le formule di presentazione e per fargli conoscere i nomi dei compagni, in classe si può proporre questo gioco: i bambini si mettono in cerchio insieme all'insegnante. L'insegnante dirà: "Ciao, io sono...". Di seguito tutti i bambini ripeteranno la stessa formula.

Dopo aver completato le schede delle pagine 18 e 19 (*Salutiamoci*), per controllare se il bambino ricorda i vari saluti, si può fare il seguente gioco:

i bambini, a turno, salutano il nuovo compagno, usando formule diverse (*Ciao, Buongiorno, Buonasera, Buonanotte*). Il bambino risponderà utilizzando il corrispettivo saluto nella sua lingua originaria.

La sezione si chiude con la presentazione delle domande cui il bambino dovrà ricorrere più di frequente. Se il bambino avesse forti difficoltà ad esprimersi, potrà essere invitato a mostrare, in caso di bisogno, la figura del libro con la domanda o l'espressione che in quel momento vorrebbe formulare.

I simboli che introducono le consegne su ogni scheda indicano:



LEGGERE



DISEGNARE



SCRIVERE



COLORARE*

* Il bambino troverà questo simbolo  solo quando sarà strettamente indispensabile per lo svolgimento dell'esercizio. Tuttavia si consiglia di far colorare tutti i disegni.

LA FILASTROCCA DEL PAESE



C'È UN PAESE IN CAPO AL MONDO
DOVE ESISTE UN GIROTONDO
DI PERSONE E DI COLORI
MAI NESSUNO NE STA FUORI.

GIRA GIRA IL GIROTONDO
NEL PAESE IN CAPO AL MONDO
PER PORTARE GIOIA E AMORE
ALLA GENTE DI OGNI COLORE.

Franca Corbelli

(www.ilpaesedeibambinichesorridono.it)

Nome _____ Classe _____ Data _____

IL MIO NOME



Disegna te stesso, poi completa e copia la frase.



IO SONO _____

Io sono _____

Nome _____ Classe _____ Data _____

LA MIA FAMIGLIA

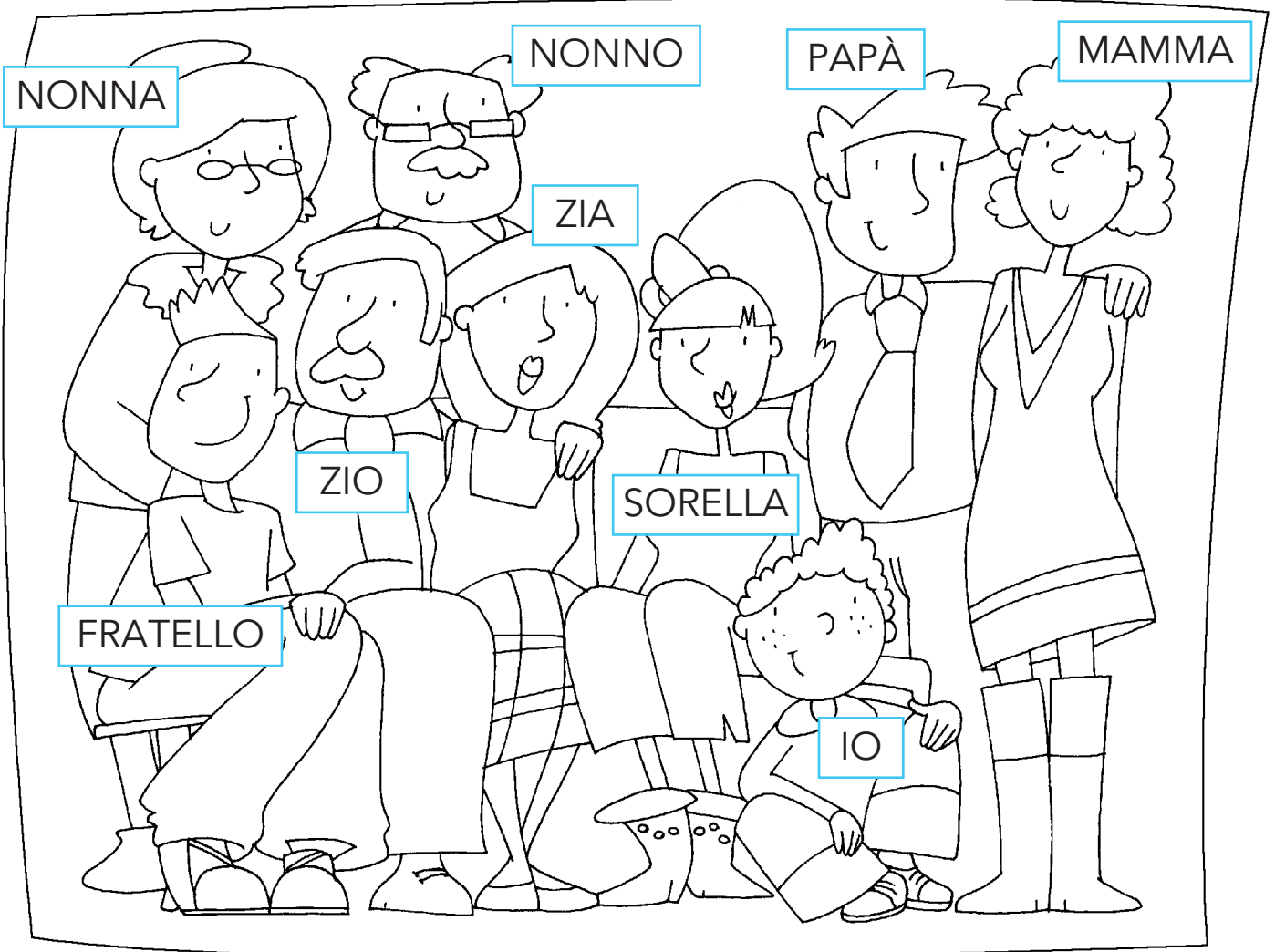

 Completa.

MIA MAMMA SI CHIAMA _____

MIO PAPÀ SI CHIAMA _____

MIO FRATELLO SI CHIAMA _____

MIA SORELLA SI CHIAMA _____

MIO NONNO SI CHIAMA _____

MIA NONNA SI CHIAMA _____

Nome _____ Classe _____ Data _____

IL MIO PAESE



Colora il tuo Paese, poi completa e copia la frase.

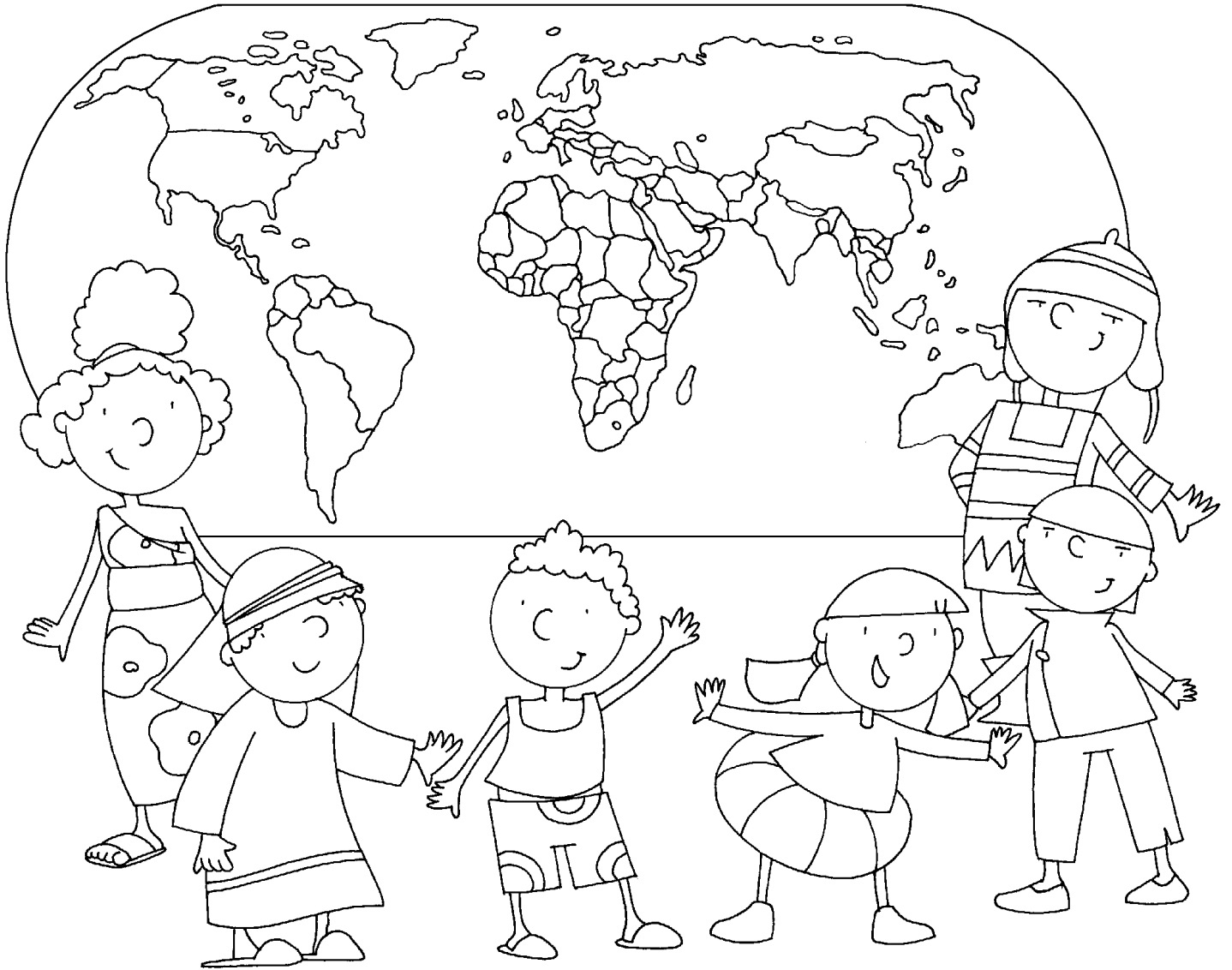

SONO NATO IN _____ E HO _____ ANNI.

Sono nato in _____

e ho _____ *anni.*

Nome _____ Classe _____ Data _____

IL VIAGGIO



Segna con una X, poi completa e copia la frase.

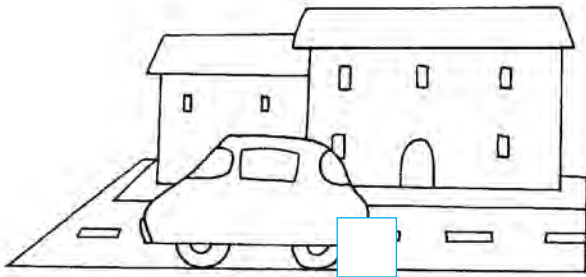

L'AUTOMOBILE

L'automobile

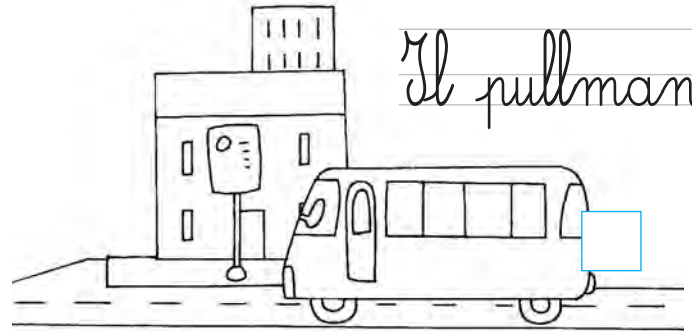

IL PULLMAN

Il pullman

L'AEREO

L'aereo



LA NAVE

La nave

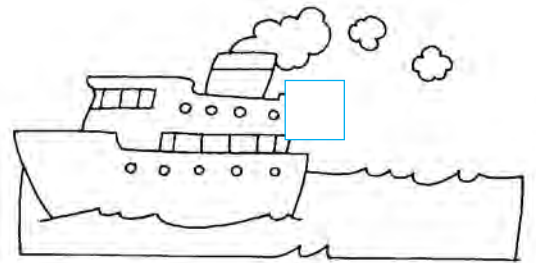

IL TRENO

Il treno

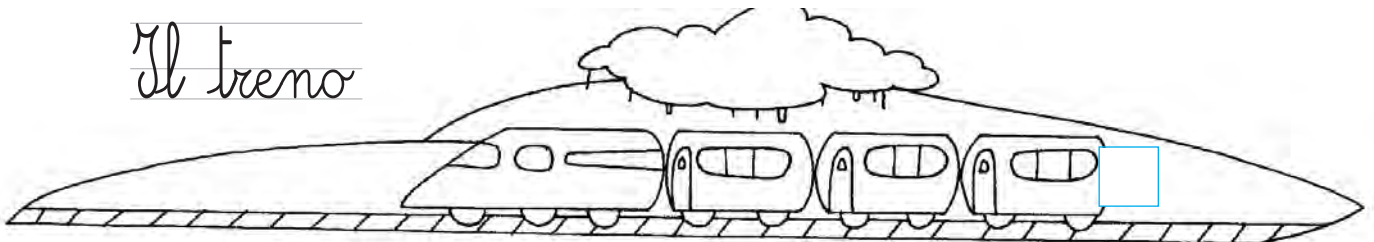

SONO ARRIVATO IN ITALIA CON _____

Sono arrivato in Italia con

Nome _____ Classe _____ Data _____

LA MIA CASA



Disegna la tua casa, poi copia la frase.

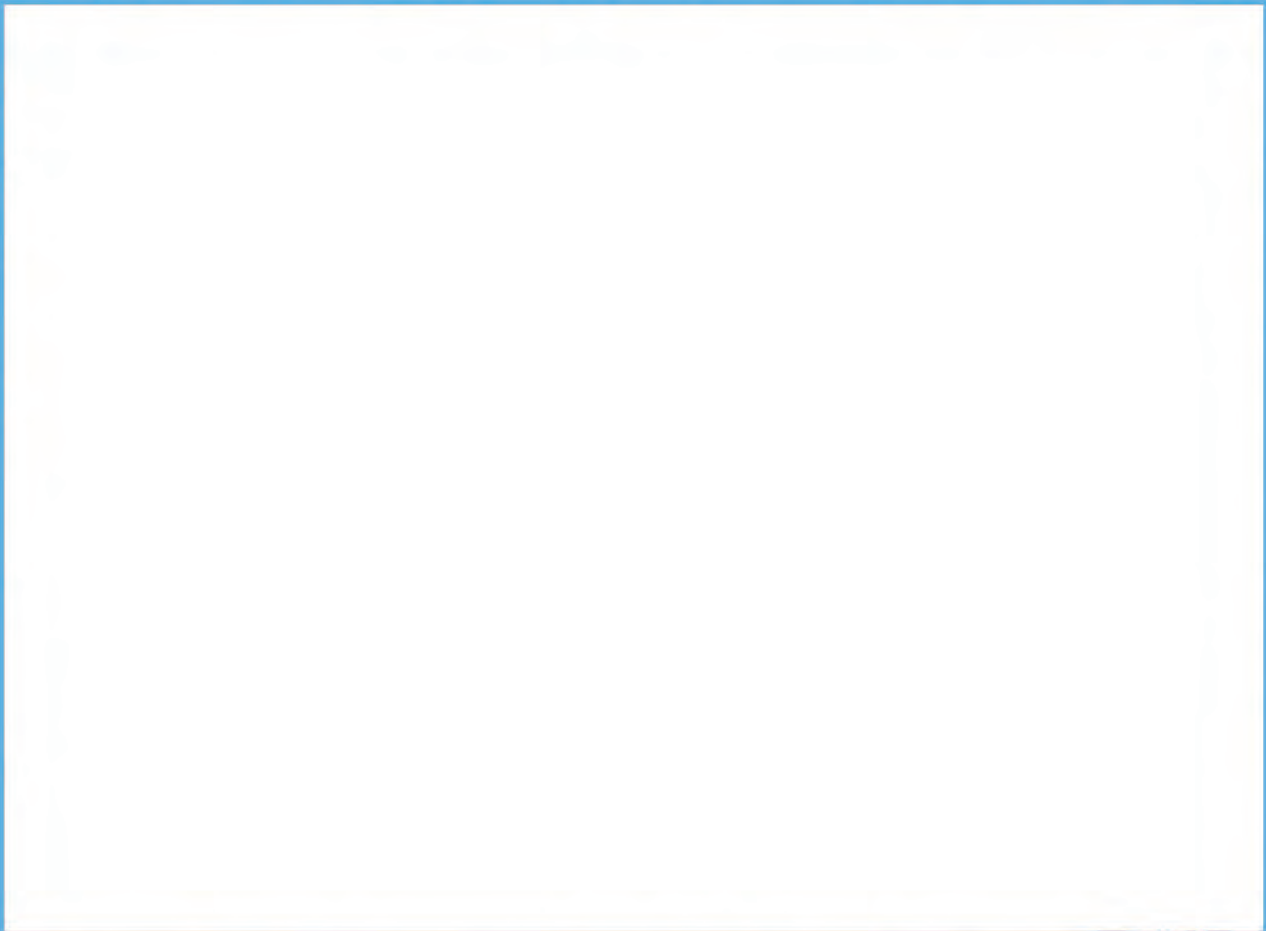

QUESTA ERA LA MIA CASA.

Questa era la mia casa.



Nome _____ Classe _____ Data _____

I MIEI COMPAGNI

● Chiedi ai compagni di scrivere il loro nome e fare un piccolo ritratto di se stessi.

CIAO, IO SONO

CIAO, IO SONO

CIAO, IO SONO

CIAO, IO SONO

CIAO, IO SONO

CIAO, IO SONO

Nome _____ Classe _____ Data _____

I MIEI COMPAGNI

● Chiedi ai compagni di scrivere il loro nome e fare un piccolo ritratto di se stessi.

CIAO, IO SONO

CIAO, IO SONO

CIAO, IO SONO

CIAO, IO SONO

CIAO, IO SONO

CIAO, IO SONO



Nome _____ Classe _____ Data _____

I MIEI COMPAGNI

● Chiedi ai compagni di scrivere il loro nome e fare un piccolo ritratto di se stessi.

CIAO, IO SONO

CIAO, IO SONO

CIAO, IO SONO

CIAO, IO SONO

CIAO, IO SONO

CIAO, IO SONO

Nome _____ Classe _____ Data _____

I MIEI INSEGNANTI



Disegna i tuoi insegnanti.

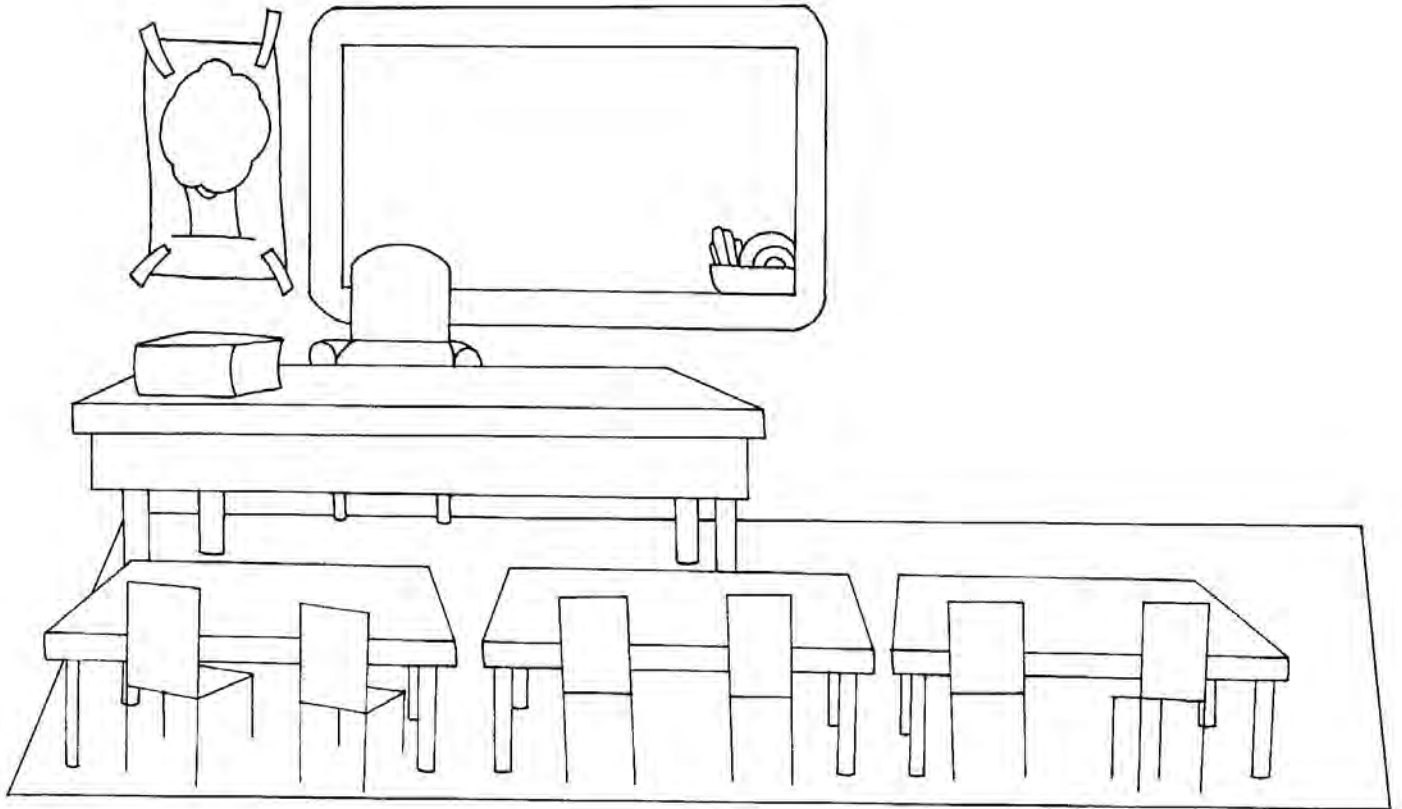

Completa e copia le frasi.

I MIEI INSEGNANTI SI CHIAMANO _____

I _____

I miei insegnanti si chiamano

I

Nome _____ Classe _____ Data _____

SALUTIAMOCI

 Copia i saluti nei fumetti.

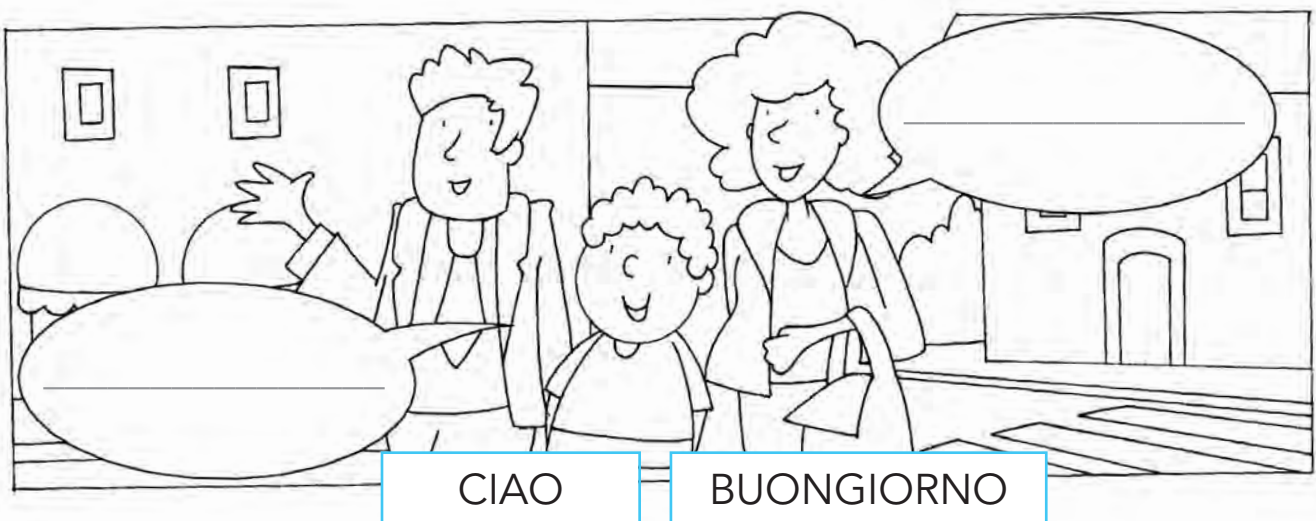
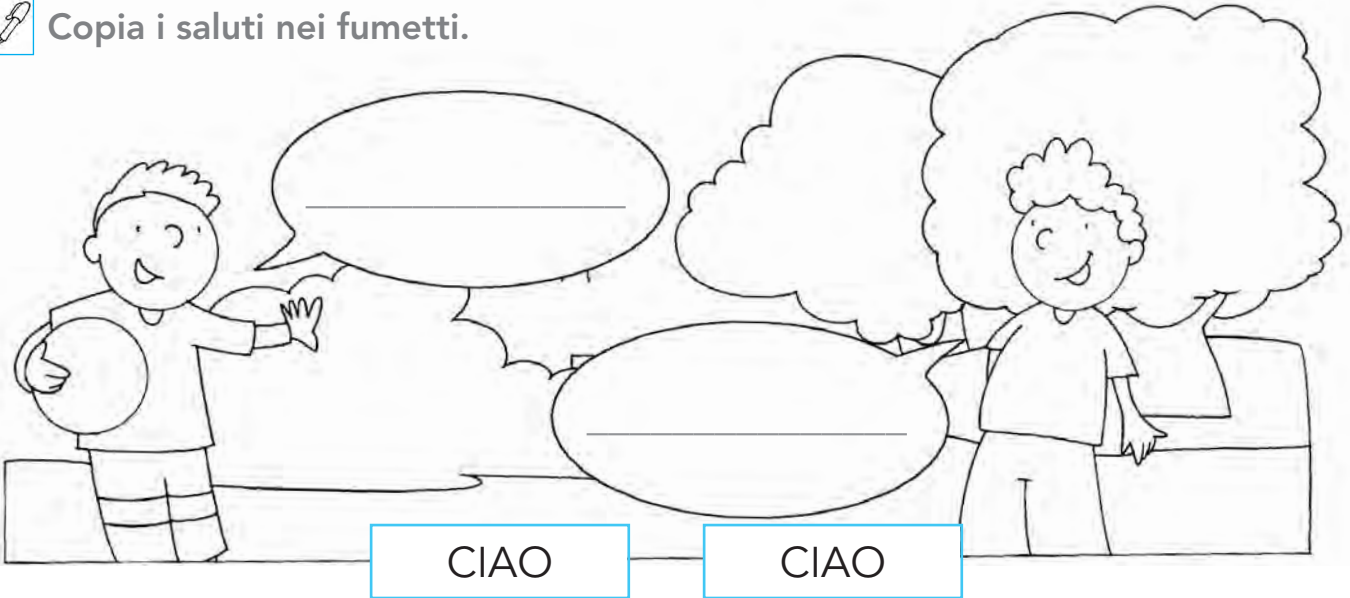

Nome _____ Classe _____ Data _____

SALUTIAMOCI

 Copia i saluti nei fumetti.

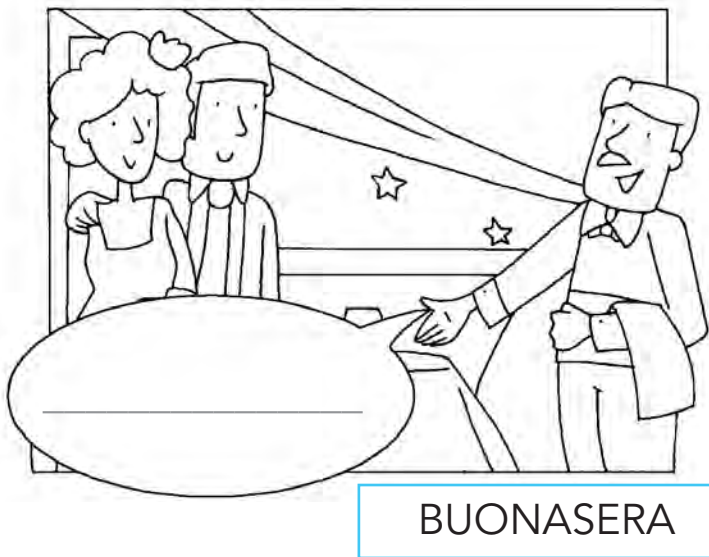

Nome _____ Classe _____ Data _____

MI PRESENTO



Segna con una X, poi completa.

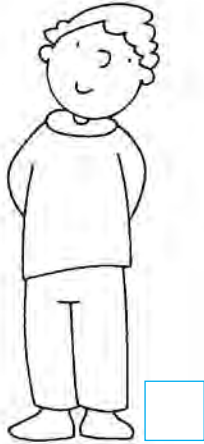

ALTO
alto



BASSO
basso



ALTA
alta



BASSA
bassa

IO SONO _____

Io sono _____

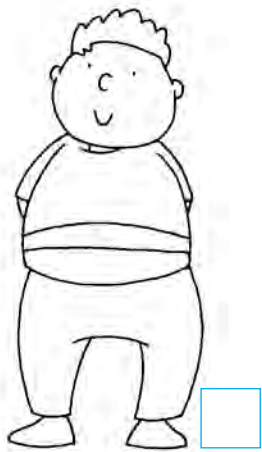

GRASSO
grasso

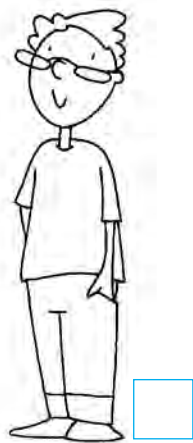

MAGRO
magro



GRASSA
grassa



MAGRA
magra

IO SONO _____

Io sono _____

Nome _____ Classe _____ Data _____

MI PRESENTO

 Segna con una X, poi completa.



CAPELLI LUNGHI
capelli lunghi



CAPELLI CORTI
capelli corti

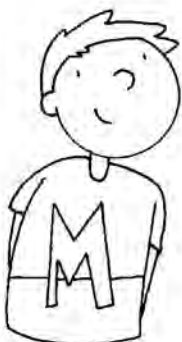

CAPELLI LISCI
capelli lisci



CAPELLI RICCI
capelli ricci

I MIEI CAPELLI SONO _____ E _____

I miei capelli sono _____ e _____



Colora gli occhi, poi completa.

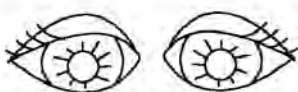

NERI

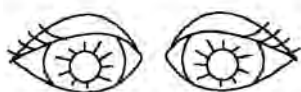

CASTANI

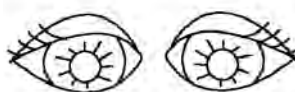

VERDI

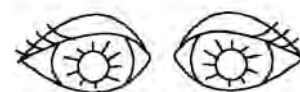

AZZURRI

I MIEI OCCHI SONO _____

I miei occhi sono _____

Nome _____ Classe _____ Data _____

MI PIACE – NON MI PIACE

 Segna con una X i cibi che ti piacciono, poi completa.



IL RISO

Il riso

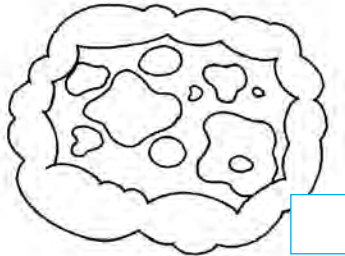

LA PIZZA

La pizza

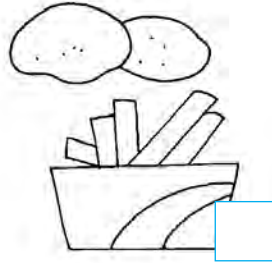

LE PATATE

Le patate



IL POLLO

Il pollo



LA PASTA

La pasta

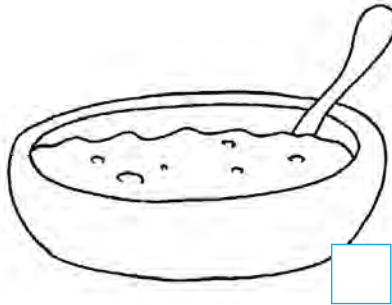

LA MINESTRA

La minestra

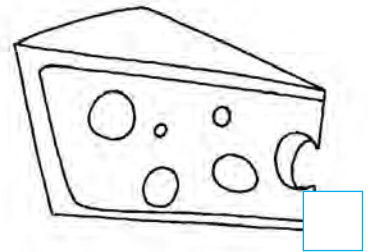

IL FORMAGGIO

Il formaggio

MI PIACE _____

Mi piace

NON MI PIACE _____

Non mi piace

Nome _____ Classe _____ Data _____

MI PIACE – NON MI PIACE

 Segna con una X ciò che ti piace fare, poi completa.

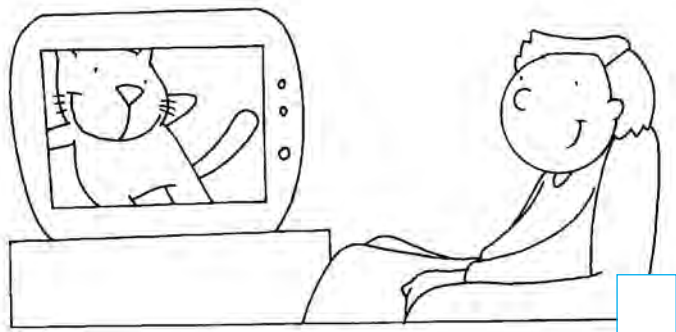

GUARDARE LA TV

Guardare la tv

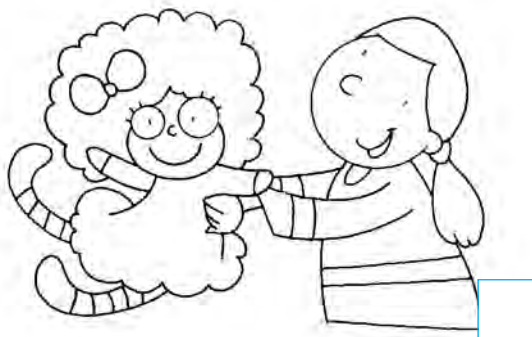

GIOCARE CON LE BAMBOLE

Giocare con le bambole



GIOCARE A CALCIO

Giocare a calcio

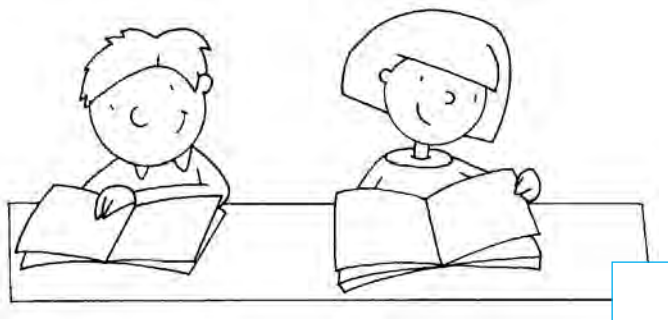

LEGGERE

Leggere

MI PIACE _____

Mi piace

NON MI PIACE _____

Non mi piace

Nome _____ Classe _____ Data _____

COME MI SENTO



Leggi e copia.



IO HO FAME.

Io ho fame.



IO HO SETE.

Io ho sete.



IO NON HO FAME.

Io non ho fame.

Nome _____ Classe _____ Data _____

COME MI SENTO



Leggi e copia.

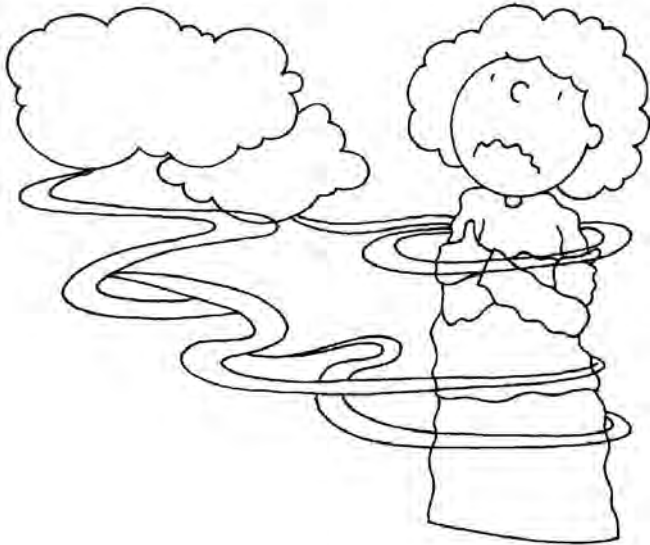

IO HO FREDDO.

Io ho freddo.

IO HO PAURA.

Io ho paura.

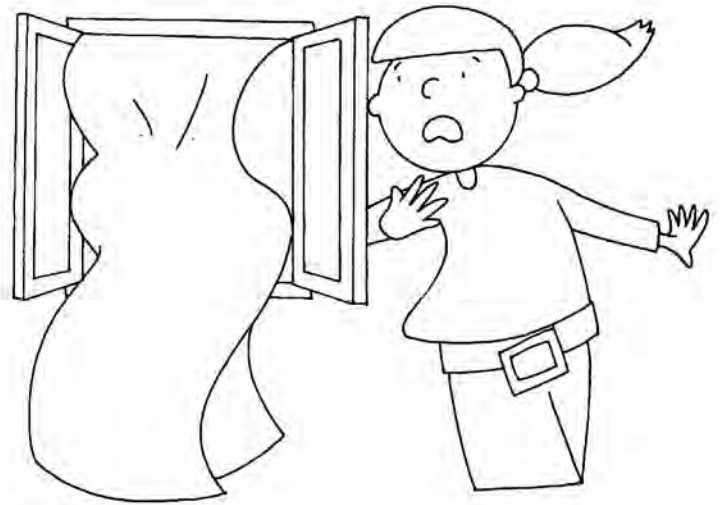

IO STO MALE.

Io sto male.



Nome _____ Classe _____ Data _____

LE PAROLE DELL'INSEGNANTE



Leggi e copia.

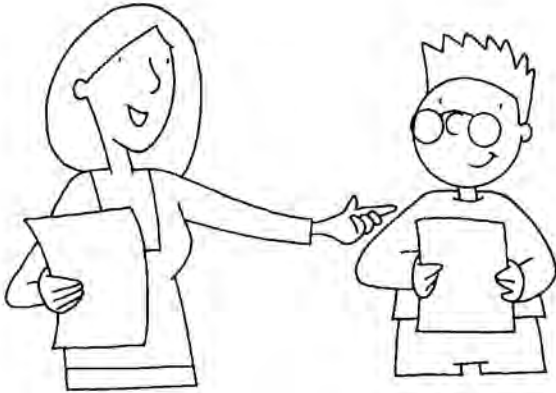

VIENI QUI.

Vieni qui.

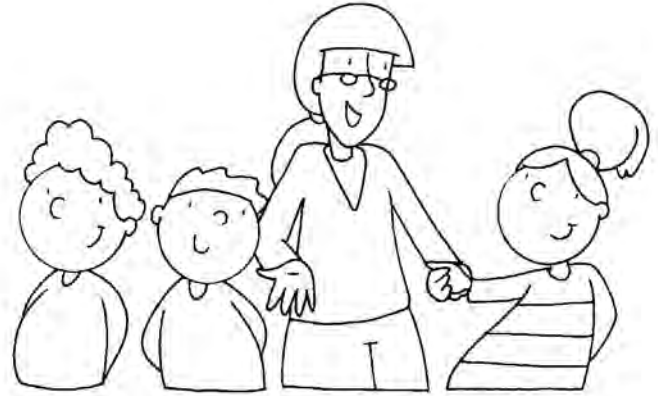

METTITI IN FILA.

Mettiti in fila.

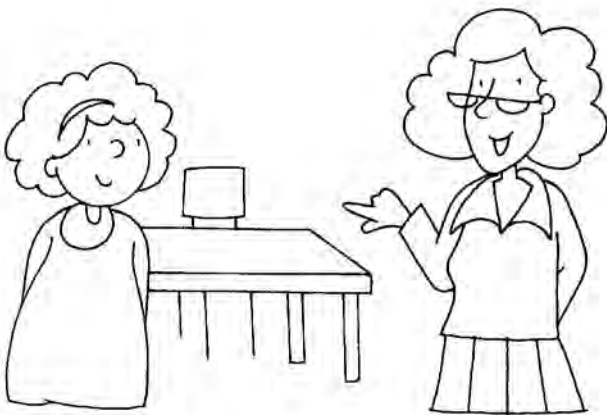

VAI AL TUO POSTO.

Vai al tuo posto.

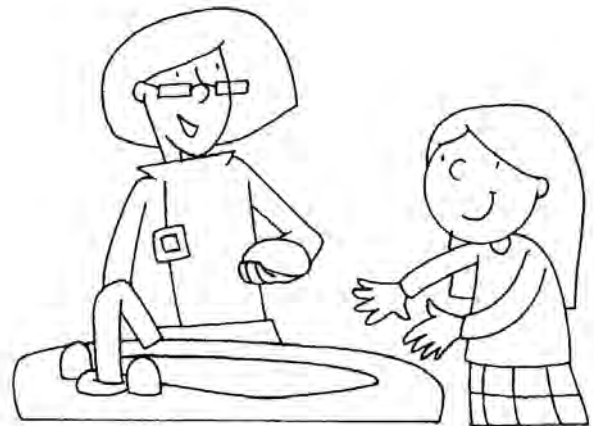

LAVA LE MANI.

Lava le mani.

Nome _____ Classe _____ Data _____

LE PAROLE DELL'INSEGNANTE



Leggi e copia.

PRENDI IL QUADERNO.

Prendi il quaderno.

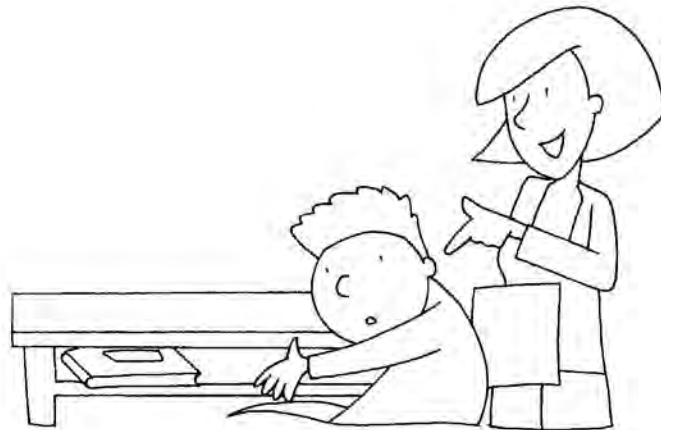

APRI IL QUADERNO.

Apri il quaderno.

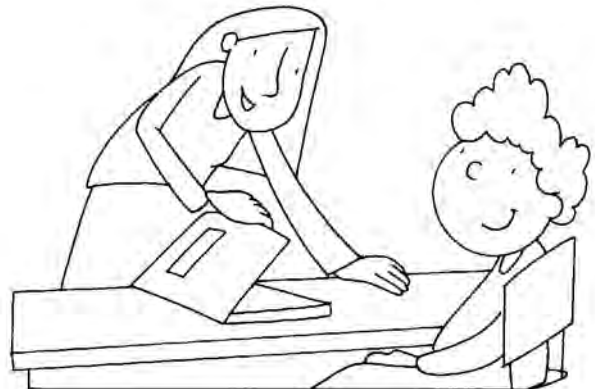

SCRIVI SUL QUADERNO.

Scrivi sul quaderno.

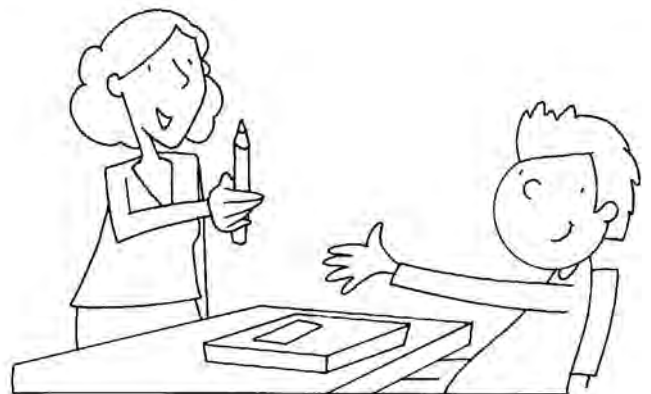

COPIA DALLA LAVAGNA.

Copia dalla lavagna.

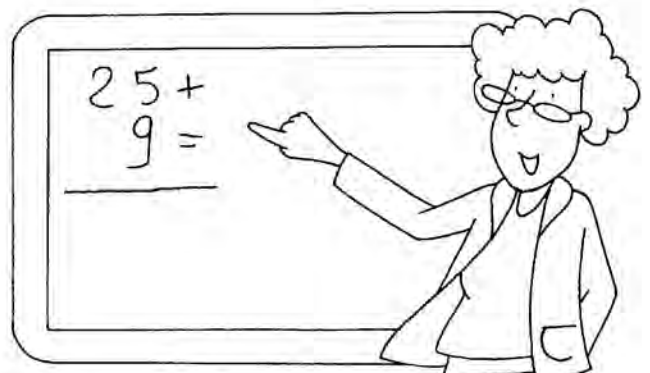

Nome _____ Classe _____ Data _____

LE DOMANDE



Leggi e copia.

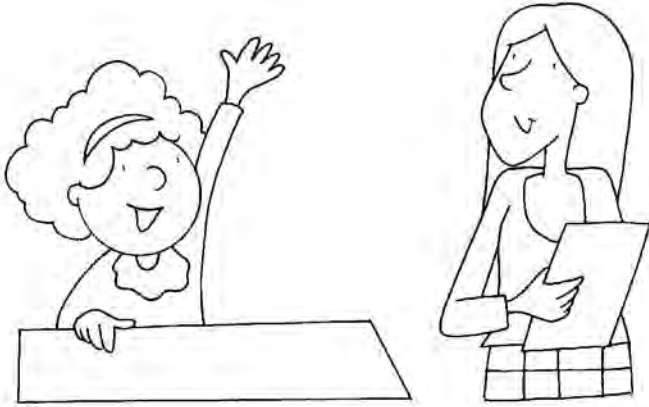

POSSO USCIRE?

Posso uscire?

POSSO ANDARE IN BAGNO?

Posso andare in bagno?

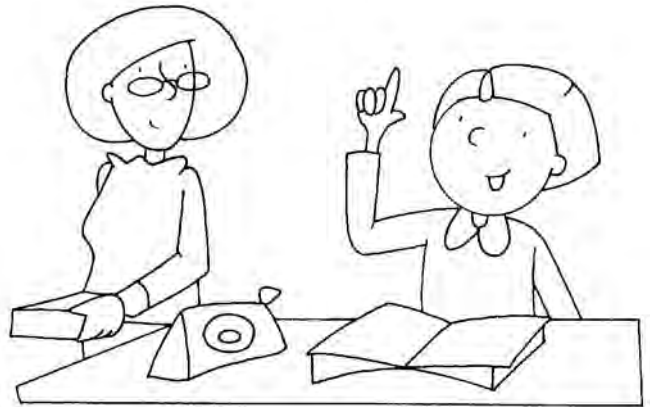

MI PRESTI UNA MATITA?

Mi presti una matita?



MI PRESTI I PENNARELLI?

Mi presti i pennarelli?

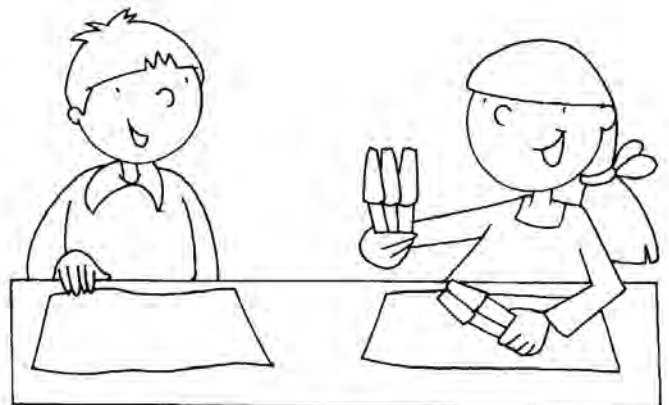

Nome _____ Classe _____ Data _____

LE DOMANDE



Leggi e copia.

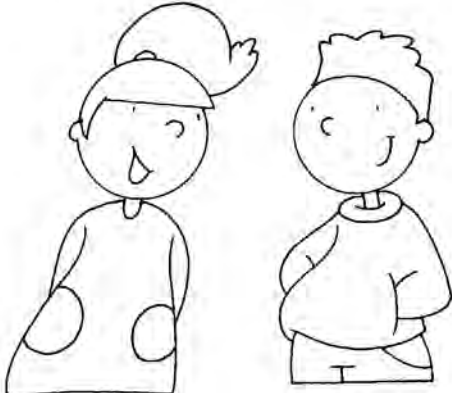

COME TI CHIAMI?

Come ti chiami?

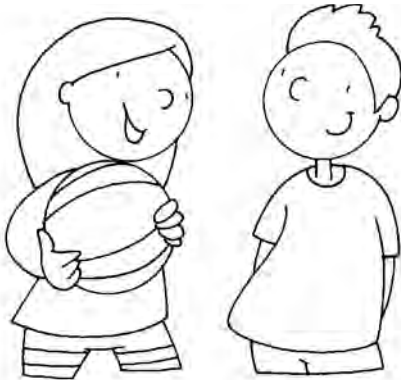

GIOCHI CON ME?

Giochi con me?

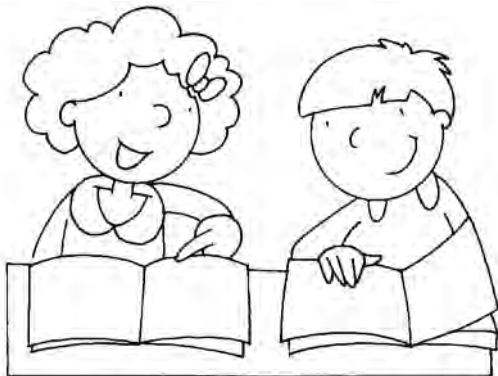

MI AIUTI?

Mi aiuti?



CHE COSA HA DETTO LA MAESTRA?

Che cosa ha detto la maestra?

Nome _____ Classe _____ Data _____

I MIEI AMICI



Disegna i compagni con cui hai fatto amicizia e scrivi i loro nomi.

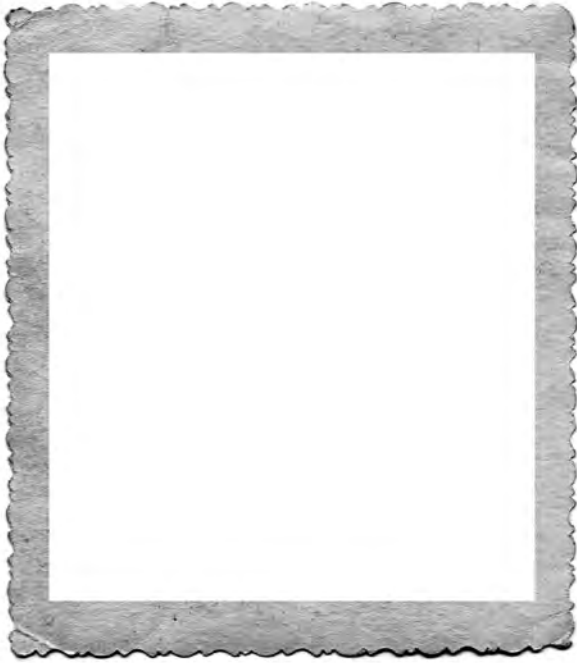

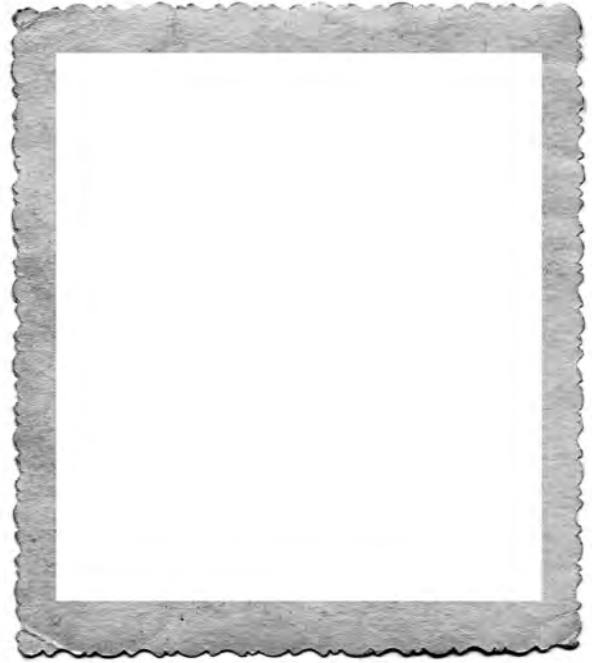

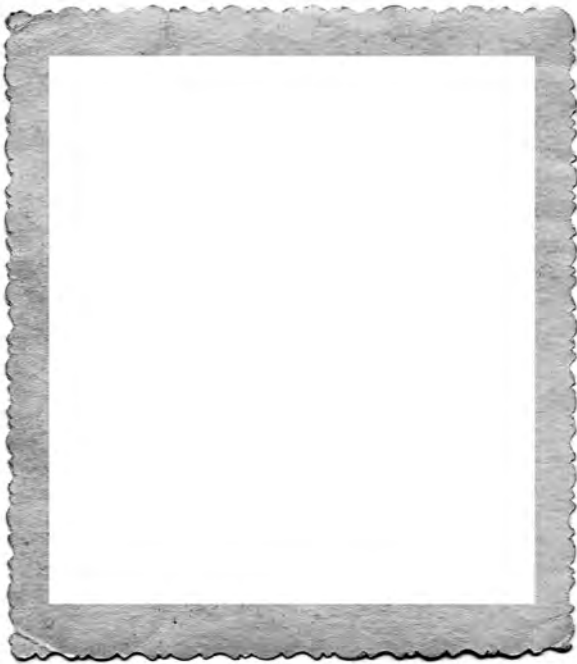

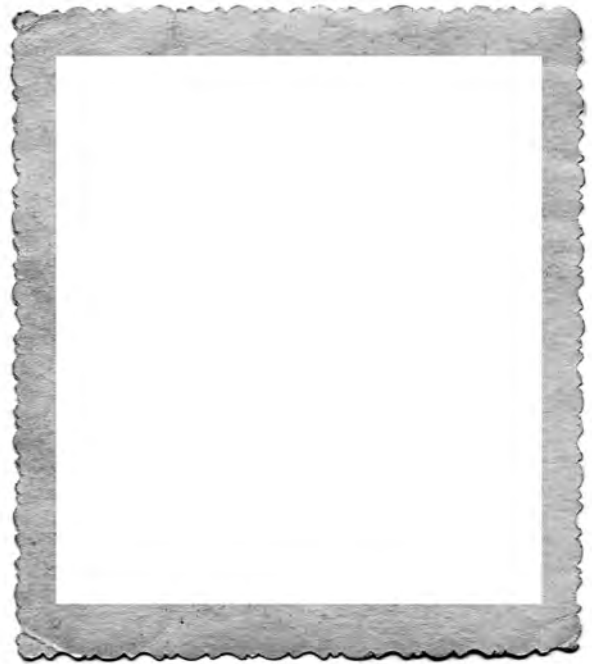

Le parole

Il bambino straniero ha bisogno di acquisire in fretta un bagaglio di vocaboli necessario per renderlo in grado di comunicare con gli altri.

Dovremo predisporre in classe alcuni cartellini con il nome degli oggetti della classe, affinché il bambino li memorizzi in fretta. Sono disponibili in commercio semplici vocabolari in cui il bambino, se non è troppo piccolo ed è già stato abituato nel suo paese d'origine ad usare un simile strumento, potrà trovare la traduzione delle parole di uso comune.

Le schede di questa sezione vogliono fornire al bambino la conoscenza del lessico minimo necessario per iniziare una proficua azione comunicativa.

È importante che noi o un compagno indichiamo al bambino straniero il nome degli oggetti e lo aiutiamo a ripeterlo più volte, in modo da raggiungere una corretta pronuncia.

Il bambino potrà poi completare le schede autonomamente per rafforzare attraverso il disegno e la scrittura la conoscenza delle parole apprese.

Nelle schede talvolta viene chiesto di copiare le parole sia in stampato maiuscolo sia in corsivo, talvolta invece viene richiesto un solo carattere. Ciò è stato predisposto affinché il bambino si abitui ad utilizzare vari caratteri di scrittura. In ogni classe, infatti, già dalla fine della classe prima vengono proposti a tutti i bambini più caratteri sia per la lettura sia per la scrittura.

Nelle pagine in cui è necessario proporre la conoscenza di più vocaboli si è preferito limitare l'esercizio di copiatura, privilegiando quello di attenzione al nome dell'oggetto.

Potremo far copiare al bambino i vari nomi anche sul quaderno.

È possibile predisporre un "memory" dei nomi, preparando dei cartellini con il nome degli oggetti e il loro disegno. Il bambino potrà giocare insieme ad uno o più compagni, cercando il corretto abbinamento tra nome e figura. In questo modo rafforzerà sia le sue conoscenze sia i rapporti interpersonali con i compagni. Il bambino straniero ha anche bisogno di apprendere i termini che indicano azioni.

In questa sezione è proposta una pagina nella quale si rappresentano situazioni in cui le azioni sono svolte, indifferentemente, da una o più persone. Essa è seguita da sei pagine in cui il soggetto delle azioni è, di volta in volta, io – tu – egli – noi – voi – essi.

Ciò permetterà al bambino di cominciare a capire che nella lingua italiana esistono differenti voci verbali a seconda del soggetto che compie l'azione.

Lo studio approfondito della coniugazione dei verbi è stato rimandato al secondo volume di quest'opera, dedicato agli alunni stranieri che hanno già raggiunto qualche conoscenza della lingua italiana.

Nome _____ Classe _____ Data _____

LA CLASSE

 Leggi.

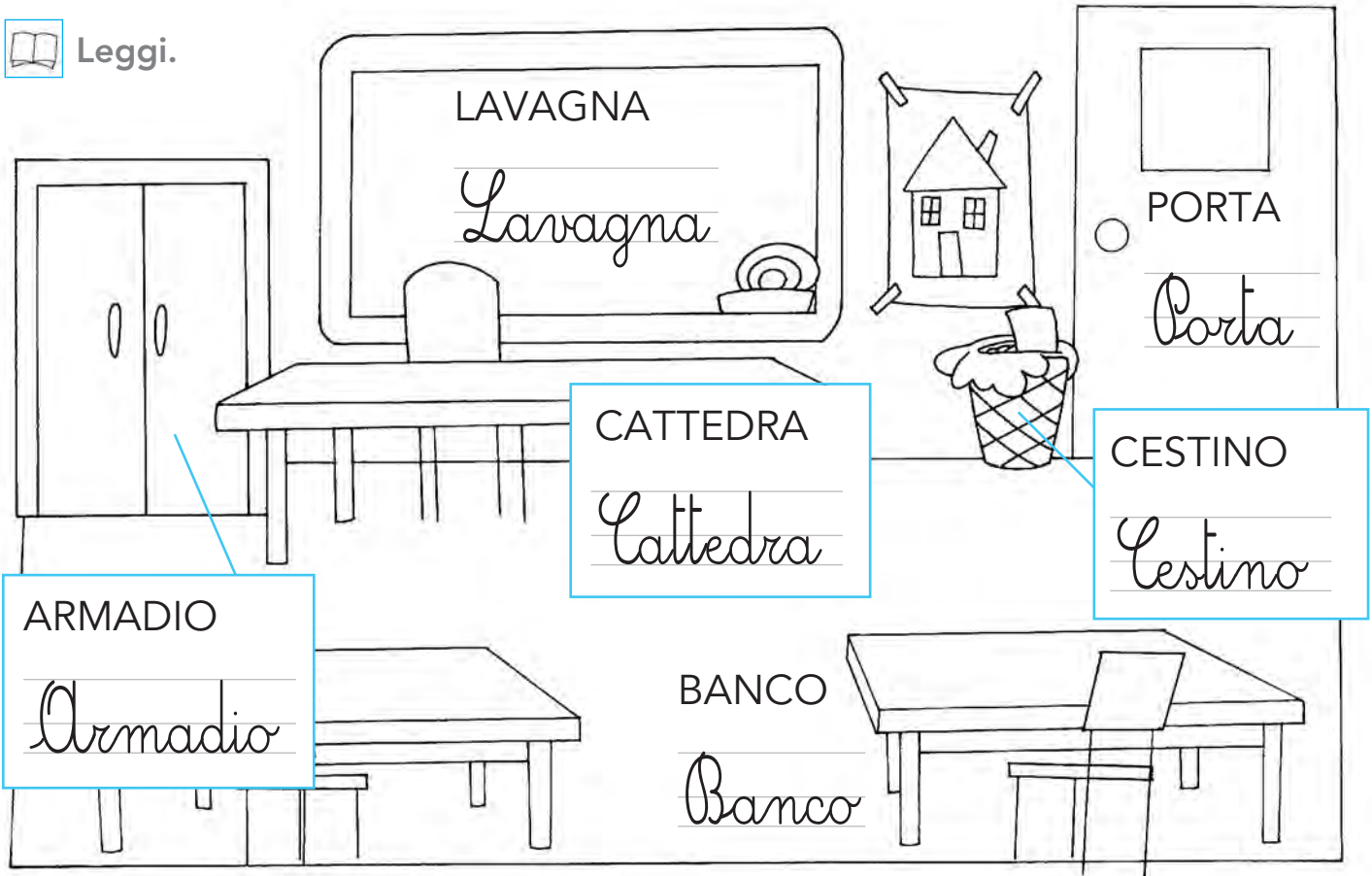

 Scrivi le parole.

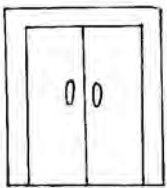

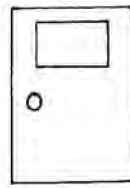



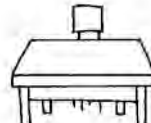

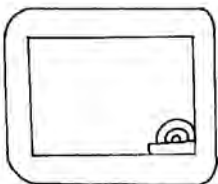

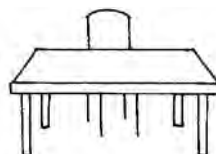

Nome _____ Classe _____ Data _____

LA SCUOLA

 Leggi.

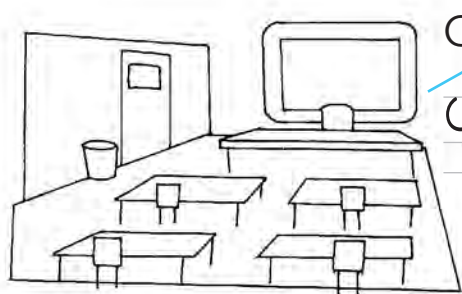

CLASSE
Classe

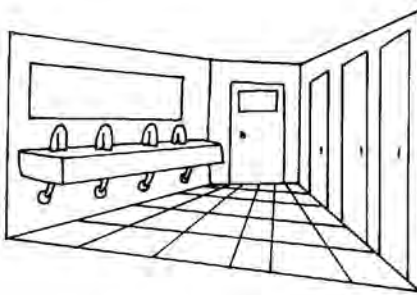

BAGNO
Bagno

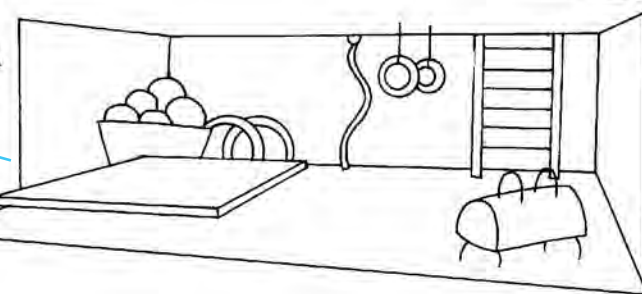

PALESTRA
Palestra

CORTILE
Cortile

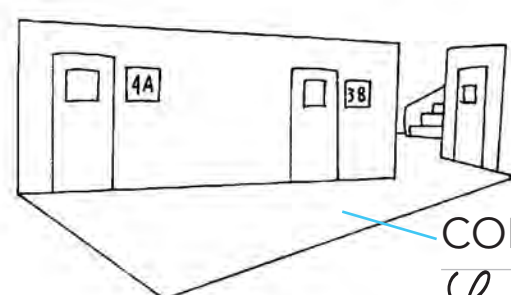

CORRIDOIO
Corridoio



 Scrivi le parole.



Nome _____ Classe _____ Data _____

LO ZAINO

 Leggi.

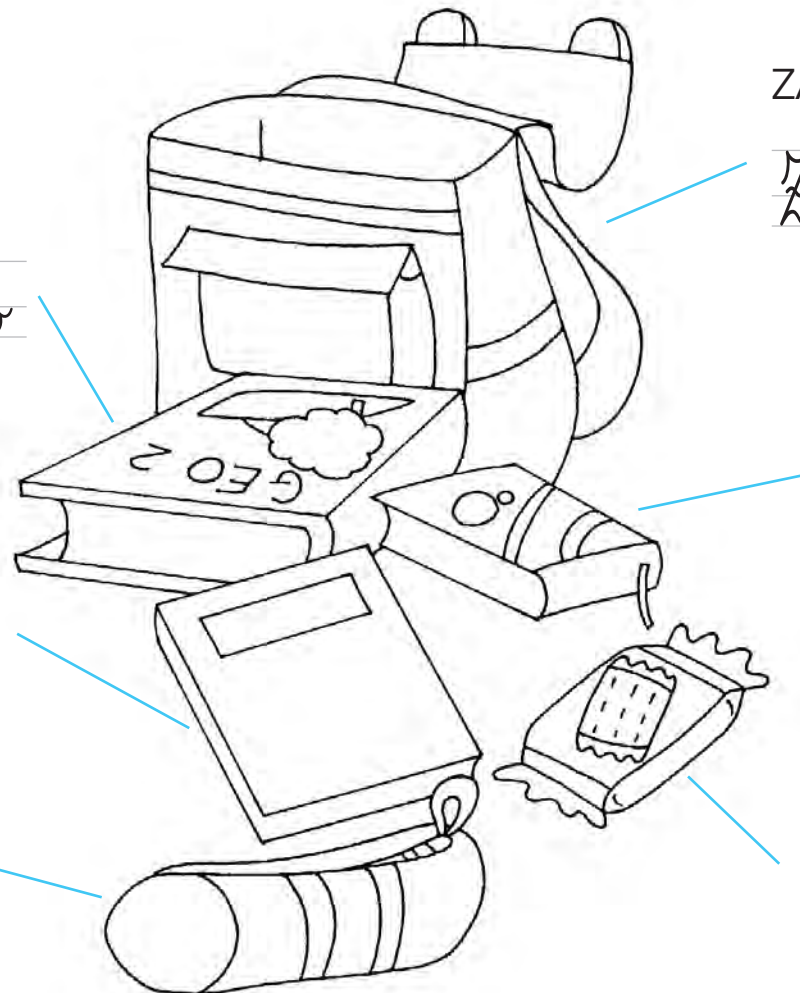

LIBRO
Libro

ZAINO
Zaino

QUADERNO
Quaderno

DIARIO
Diario

ASTUCCIO
Astuccio

MERENDA
Merenda

 Scrivi le parole.



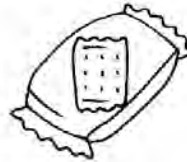





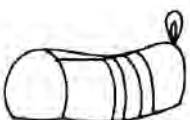



Nome _____ Classe _____ Data _____

L'ASTUCCIO

 Leggi.

MATITA

Matita

GOMMA

Gomma

PENNA

Penna

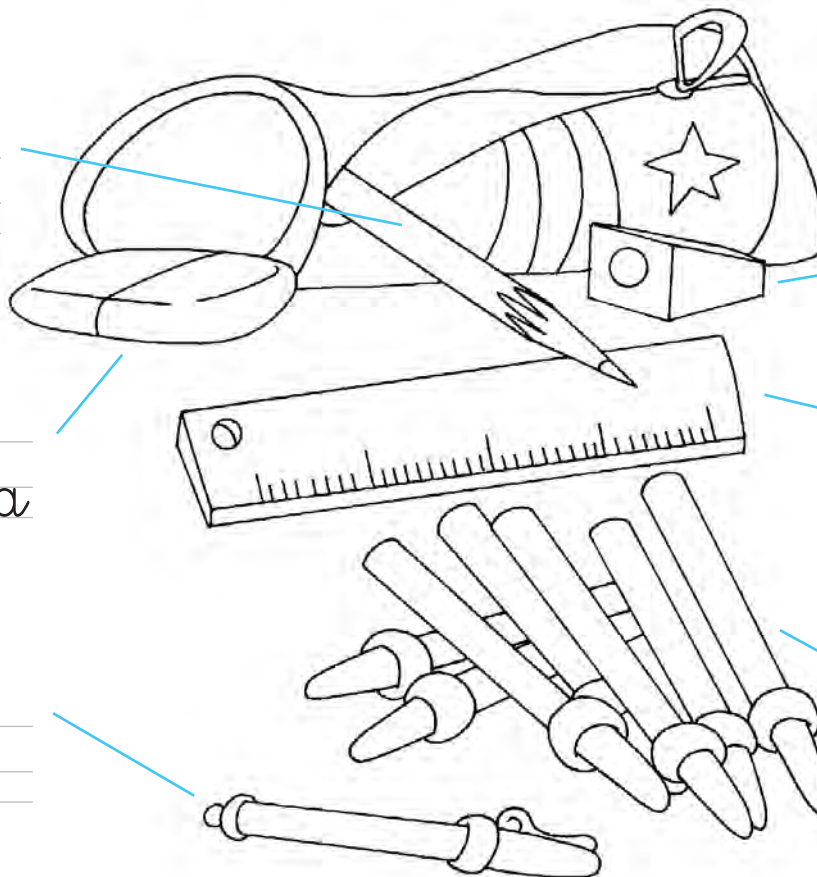

TEMPERINO

Temperino

RIGHELLO

Righello

PENNARELLI

Pennarelli

 Scrivi le parole.



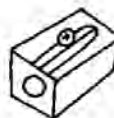









Nome _____ Classe _____ Data _____

LE AZIONI NELLA SCUOLA

 Leggi.

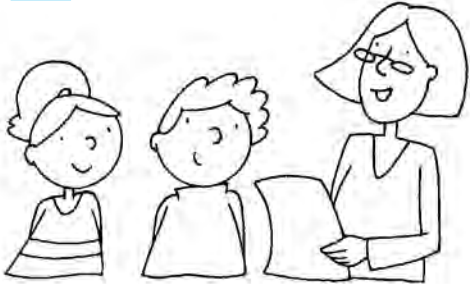

I BAMBINI ASCOLTANO LA MAESTRA.

I bambini *ascoltano* la maestra.

LIA PARLA CON OMAR.

Lia *parla* con Omar.

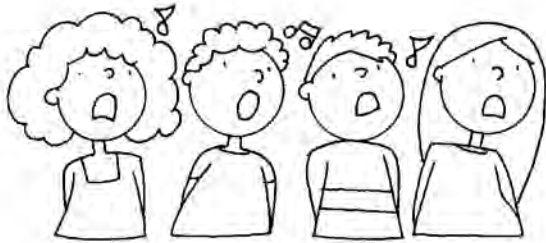
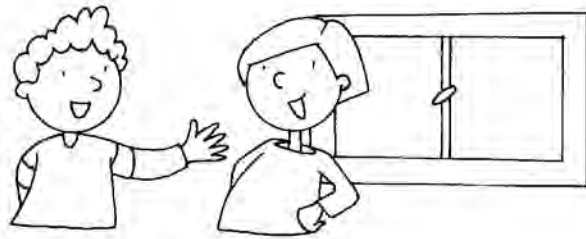

I BAMBINI CANTANO.

I bambini *cantano*.

 Scrivi le frasi.



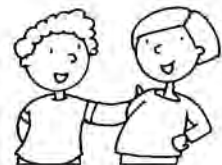



Nome _____ Classe _____ Data _____

LE AZIONI NELLA SCUOLA



Leggi.

TU TEMPERI.

Tu temperi.

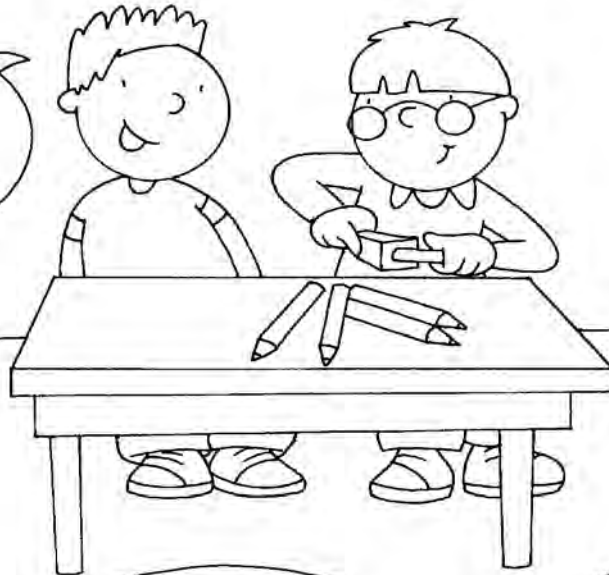

NOI SCRIVIAMO.

Noi scriviamo.

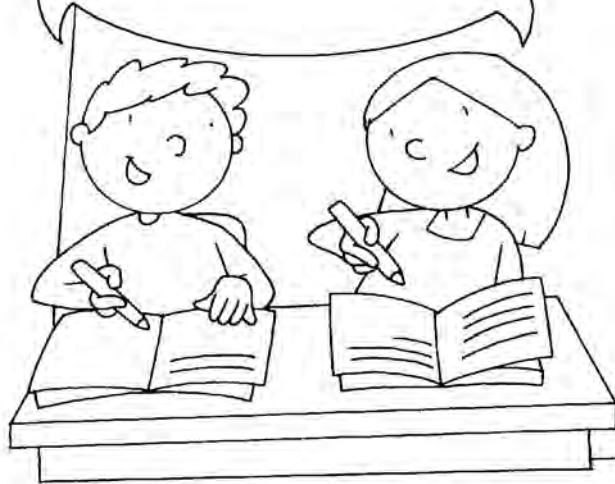

IO LEGGO.

Io leggo.

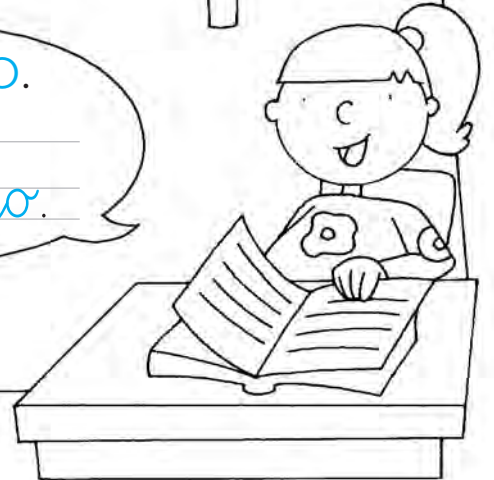

Scrivi le frasi.



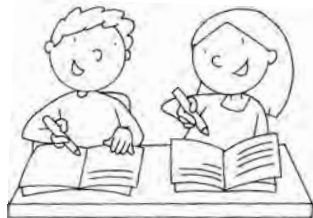



Nome _____ Classe _____ Data _____

DOV'È?

 Leggi.

IL BANCO È VICINO ALLA CATTEDRA.

Il banco è vicino alla cattedra.

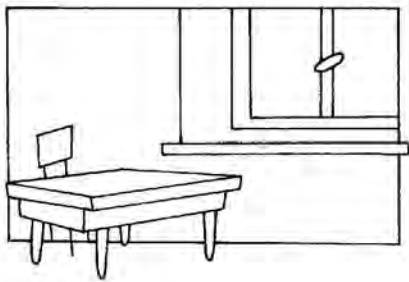
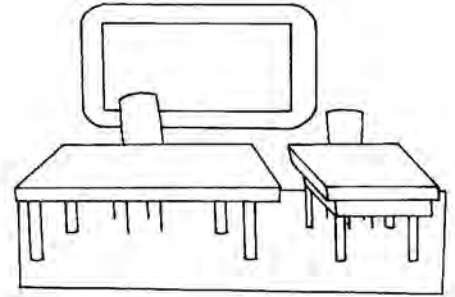

IL BANCO È VICINO ALLA FINESTRA.

Il banco è vicino alla finestra.

IL CESTINO È LONTANO DALLA PORTA.

Il cestino è lontano dalla porta.

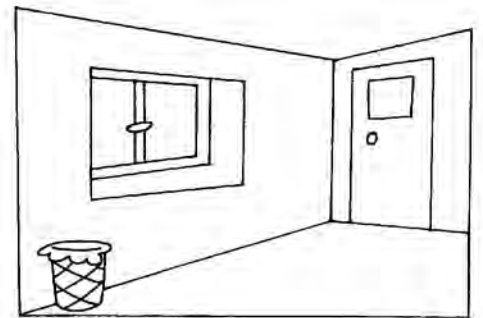

 Completa.

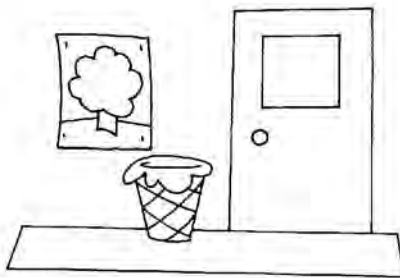

IL CESTINO È _____ ALLA PORTA.

Il cestino è _____ alla porta.

LA CATTEDRA È _____ DALLA FINESTRA.

La cattedra è _____ dalla finestra.

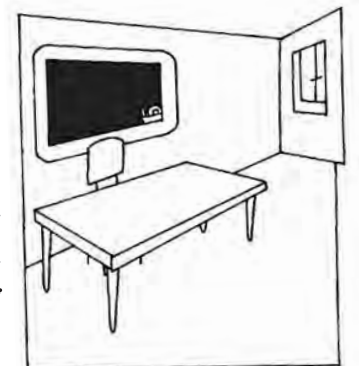

Nome _____ Classe _____ Data _____

DOV'È?



Leggi.

IL QUADERNO È **SUL** BANCO.

Il quaderno è **sul** banco.

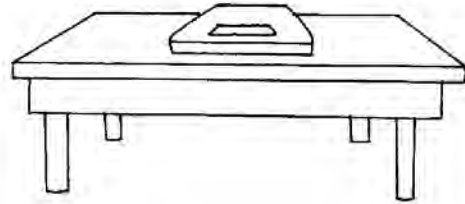

IL QUADERNO È **SOTTO** IL BANCO.

Il quaderno è **sotto** il banco.

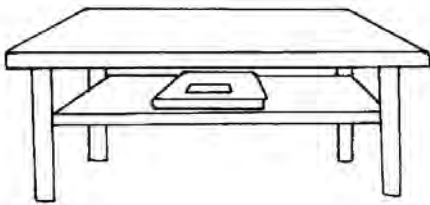

LA LAVAGNA È **DIETRO** ALLA CATTEDRA.

La lavagna è **dietro** alla cattedra.

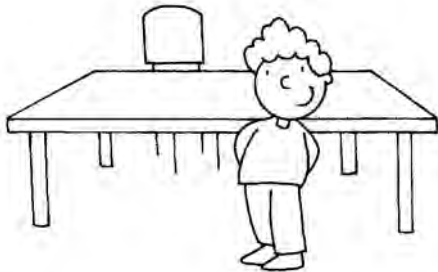
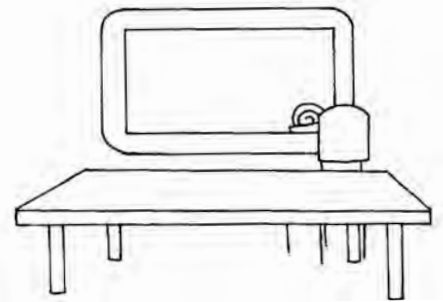

CARLOS È **DAVANTI** ALLA CATTEDRA.

Carlos è **davanti** alla cattedra.



Completa.

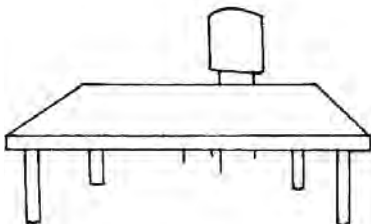

LA SEDIA È _____ ALLA CATTEDRA.

La sedia è _____ alla cattedra.

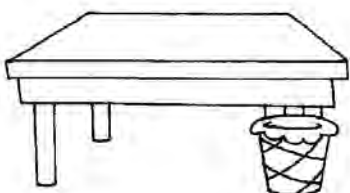

IL CESTINO È _____ AL BANCO.

Il cestino è _____ al banco.

Nome _____ Classe _____ Data _____

I COLORI



Leggi e colora.

IL  È ROSSO.

IL FUOCO È ROSSO.

Il fuoco è rosso.



IL  È BLU.

IL MARE È BLU.

Il mare è blu.

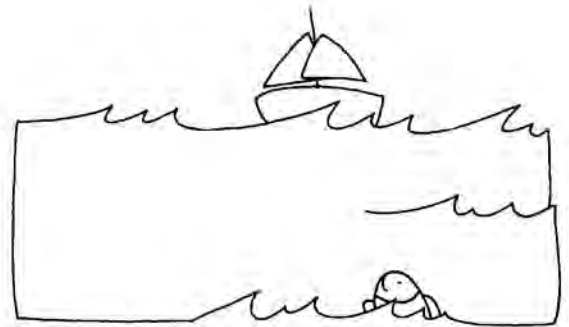

L'  È VERDE.

L'ERBA È VERDE.

L'erba è verde.



Scrivi le frasi.



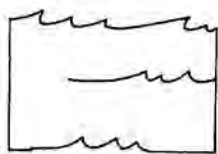





Nome _____ Classe _____ Data _____

I COLORI

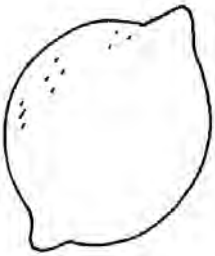

Leggi e colora.



IL  È GIALLO.
IL LIMONE È GIALLO.

Il limone è *giallo*.

IL  È NERO.
IL GATTO È NERO.

Il gatto è *nero*.

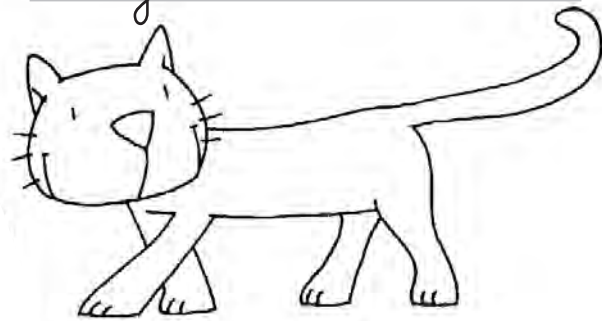

IL  È AZZURRO.
IL CIELO È AZZURRO.

Il cielo è *azzurro*.

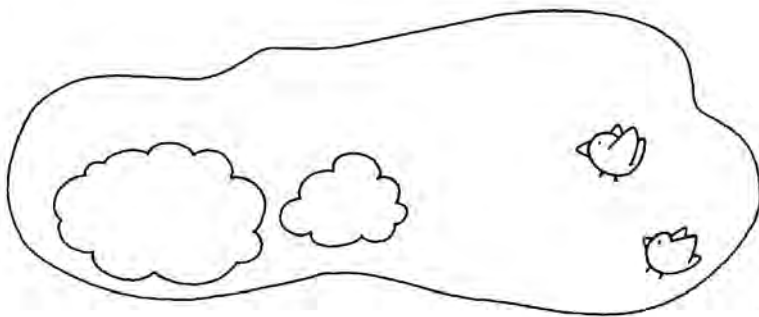

Scrivi le frasi.



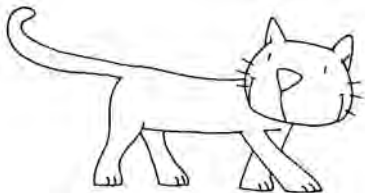



Nome _____ Classe _____ Data _____

I COLORI



Leggi e colora.

IL  È MARRONE.

IL RAMO È MARRONE.



Il ramo è marrone.

L'  È ARANCIONE.

L'ARANCIA È ARANCIONE.

L'arancia è arancione.

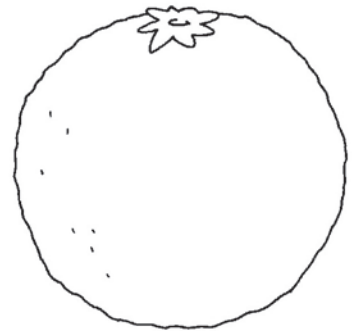

Leggi e colora.



Nome _____ Classe _____ Data _____

LA CASA



Leggi.

BAGNO

Bagno

CAMERA DA LETTO

Camera da letto



SOGGIORNO

Soggiorno

CUCINA

Cucina



Completa.



IO MANGIO IN _____

Io mangio in _____



IO DORMO IN _____

Io dormo in _____



IO GUARDO LA TELEVISIONE IN _____

Io guardo la televisione in _____



IO MI LAVO IN _____

Io mi lavo in _____

Nome _____ Classe _____ Data _____

LA CUCINA

 Leggi.



PIATTO

Piatto

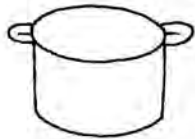

PENTOLA

Pentola



CUCCHIAIO

Cucchiaio



BOTTIGLIA

Bottiglia

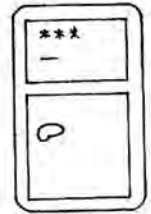

FRIGORIFERO

Frigorifero



FORCHETTA

Forchetta

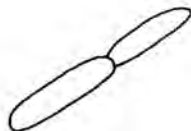

COLTELLO

Coltello



BICCHIERE

Bicchiere



TAZZA

Tazza

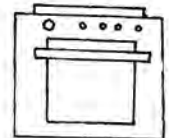

FORNO

Forno

 Scrivi.

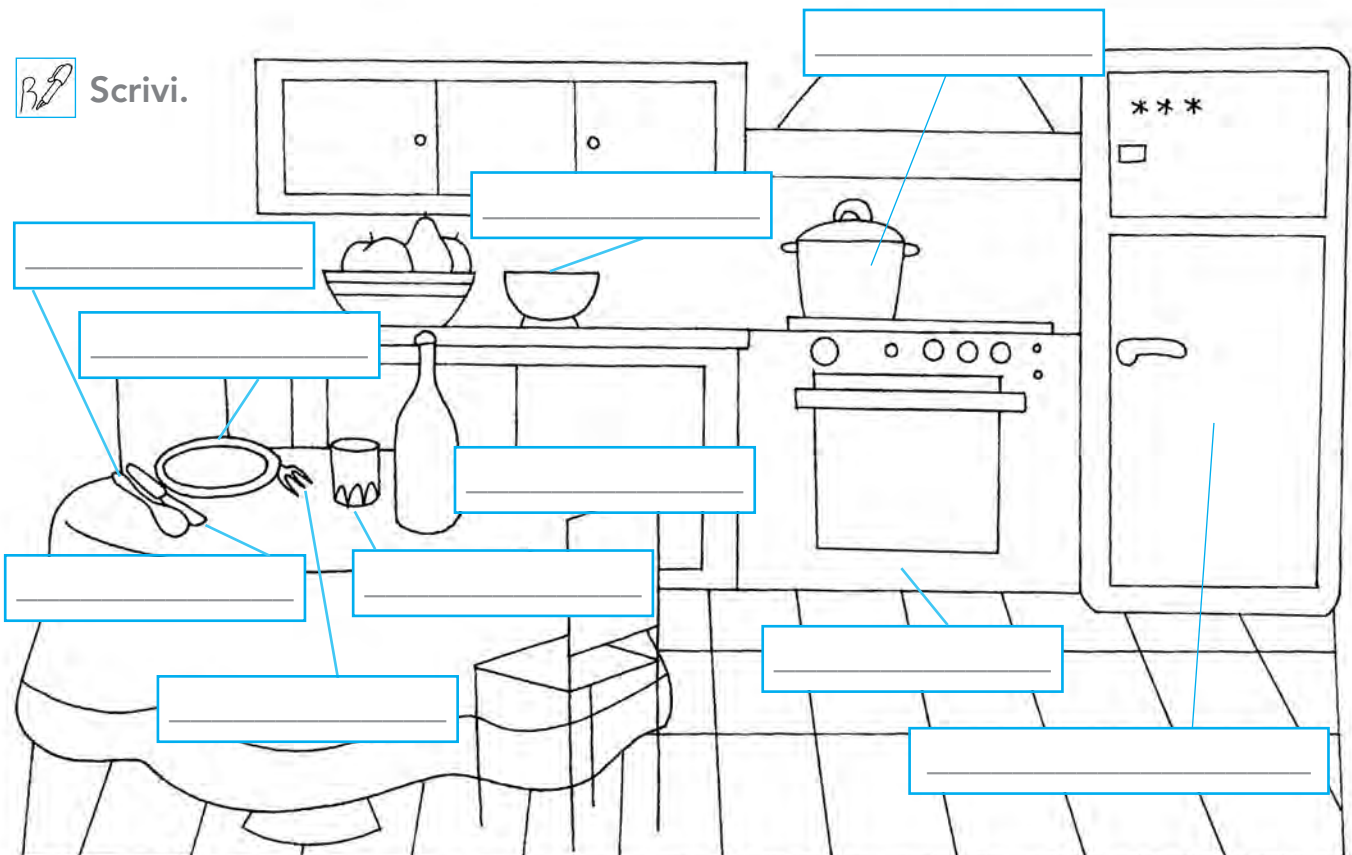

Nome _____ Classe _____ Data _____

IL SOGGIORNO

 Leggi.

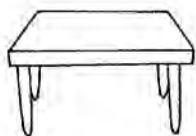

TAVOLO

Tavolo

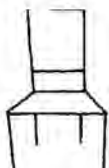

SEDIA

Sedia

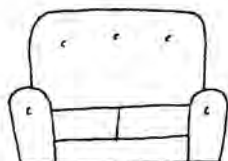

DIVANO

Divano

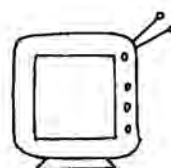

TELEVISIONE

Televisione

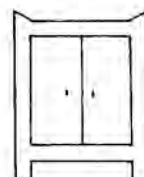

MOBILE

Mobile



QUADRO

Quadro

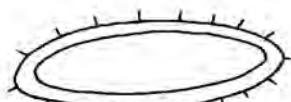

TAPPETO

Tappeto

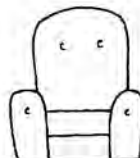

POLTRONA

Poltrona



COMPUTER

Computer

 Scrivi.

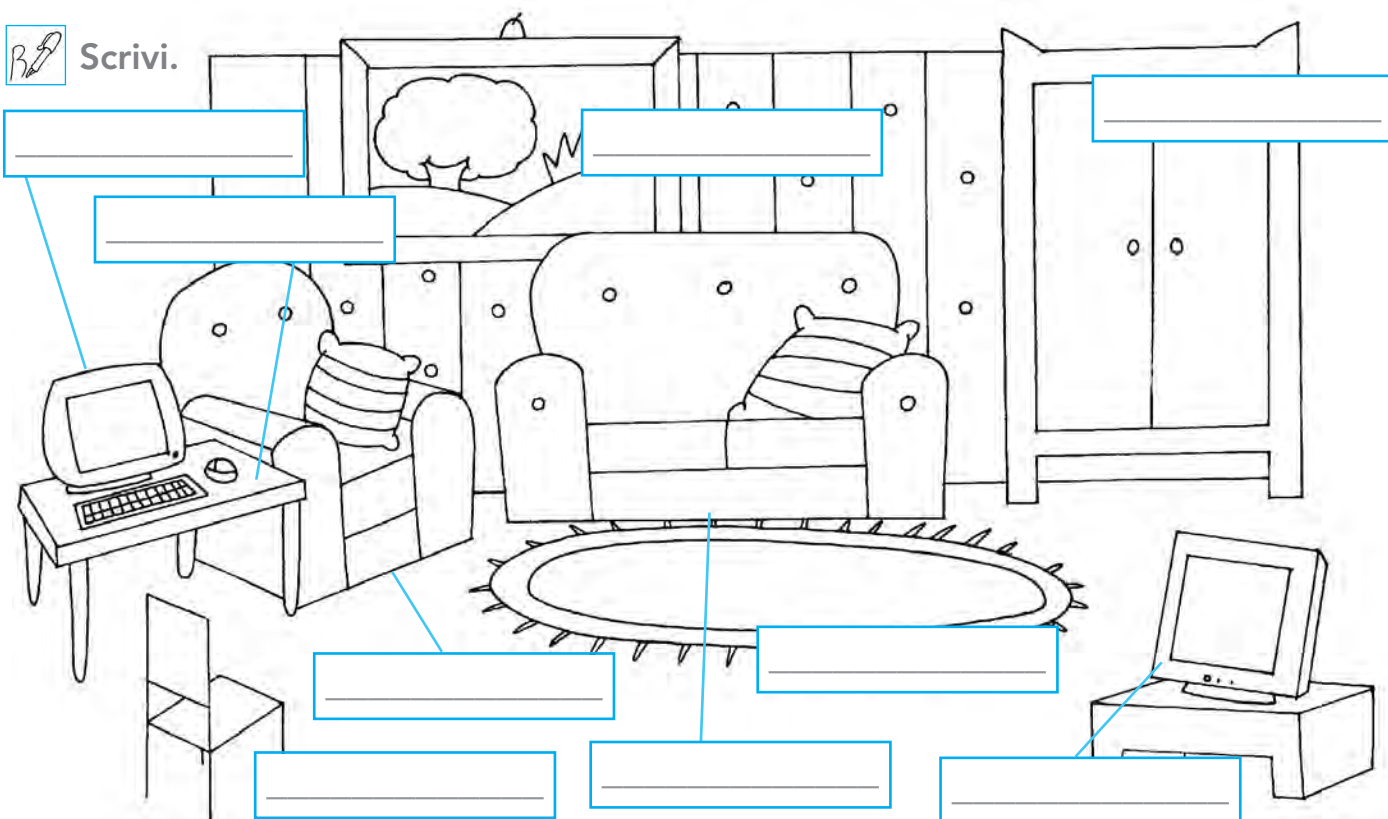

Nome _____ Classe _____ Data _____

LA CAMERA DA LETTO

 Leggi.

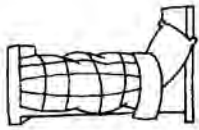

LETTO

Letto



CUSCINO

Cuscino

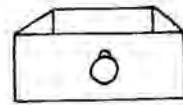

CASSETTO

Cassetto



LAMPADA

Lampada

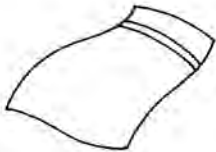

LENZUOLA

Lenzuola

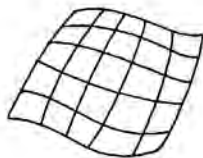

COPERTA

Coperta

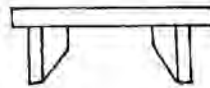

MENSOLA

Mensola

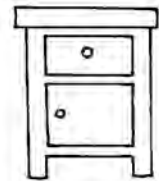

COMODINO

Comodino

 Scrivi.

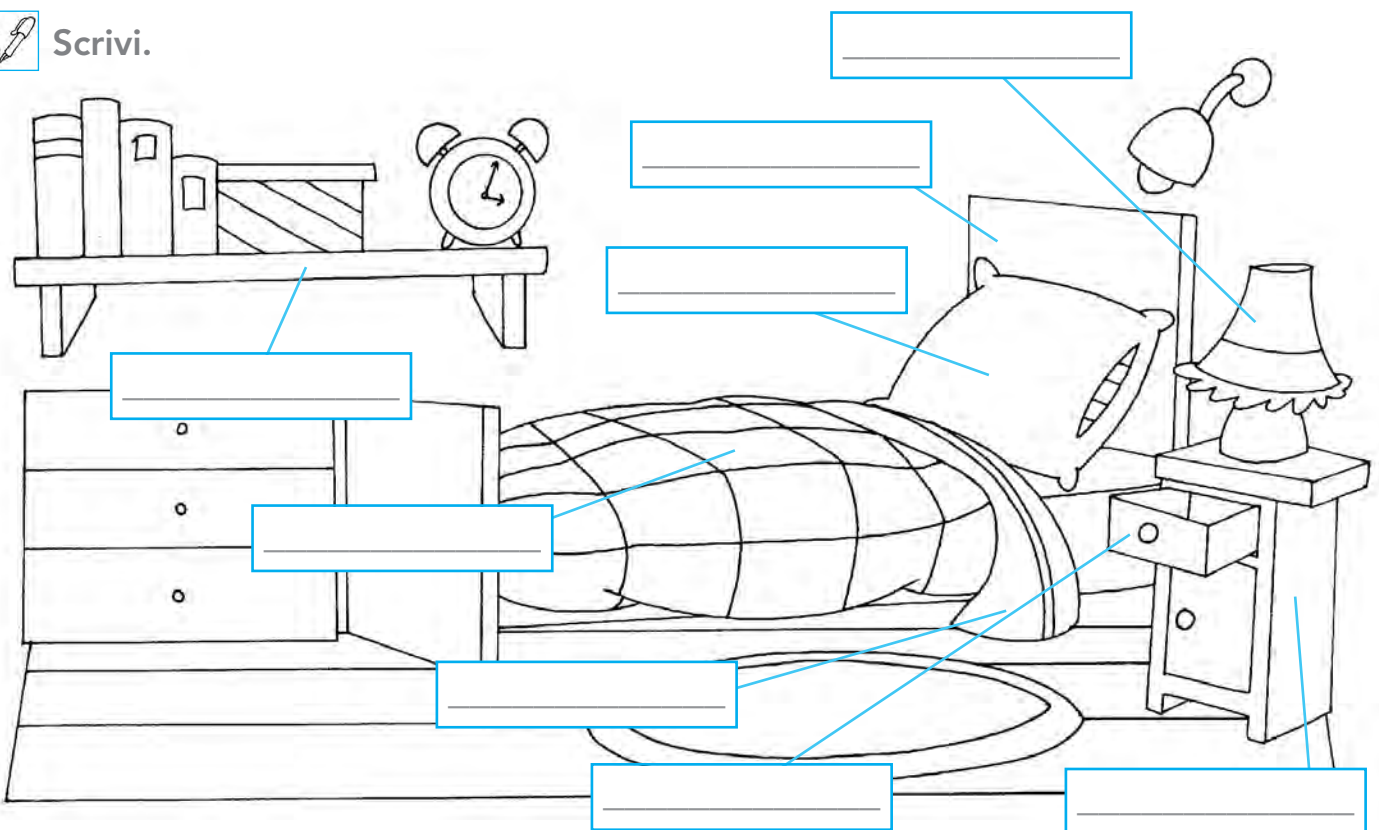

Nome _____ Classe _____ Data _____

IL BAGNO

 Leggi.

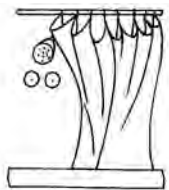

DOCCIA



LAVABO



ASCIUGAMANO



SAPONE

Doccia

Lavabo

Asciugamano

Sapone



SPAZZOLINO

Spazzolino

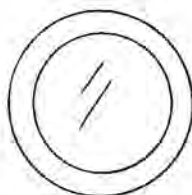

SPECCHIO

Specchio



DENTIFRICIO

Dentifricio



PETTINE

Pettine

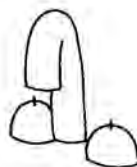

RUBINETTO

Rubinetto

 Scrivi.

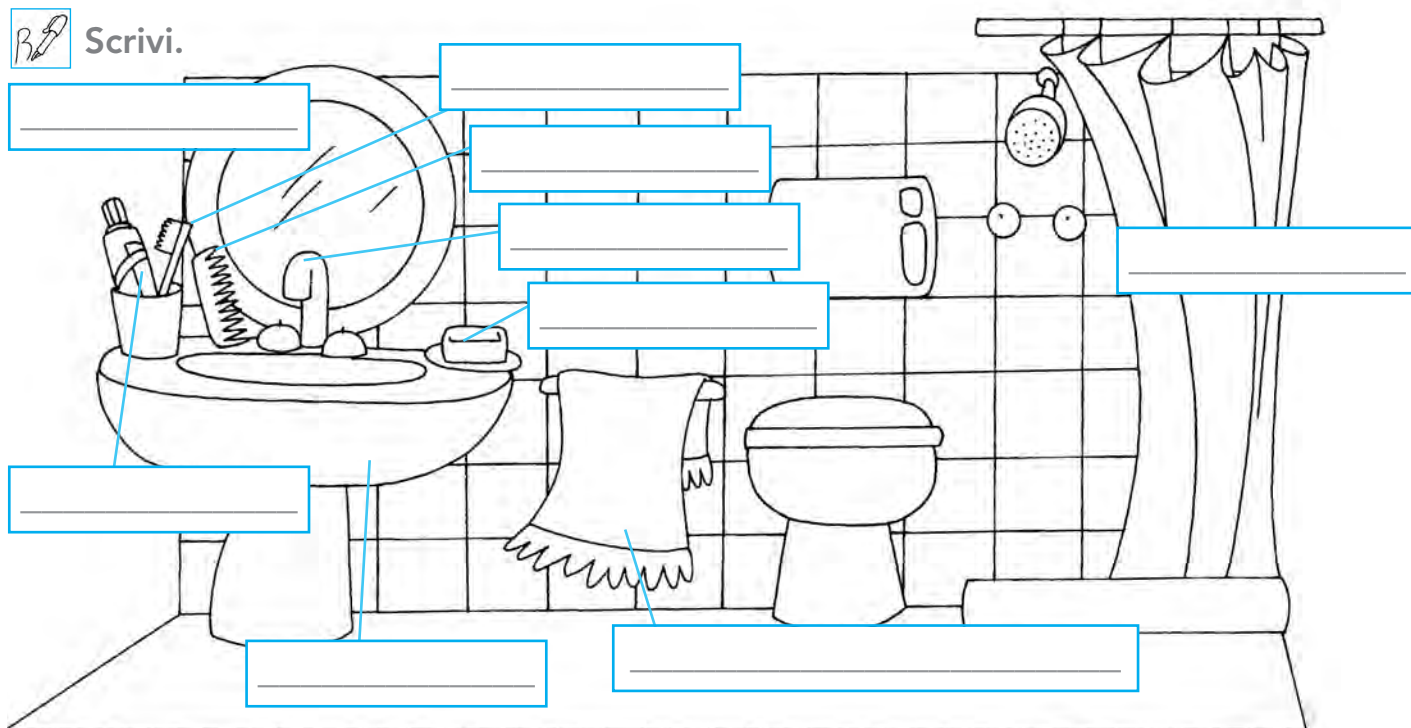

Nome _____ Classe _____ Data _____

I VESTITI

 Leggi.



CAMICIA

Camicia



GONNA

Gonna



PANTALONI

Pantaloni



SCIARPA

Sciarpa



CALZE

Calze

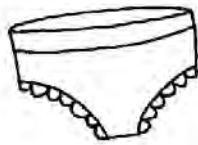

MUTANDE

Mutande



CANOTTIERA

Canottiera



MAGLIETTA

Maglietta

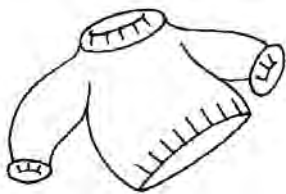

MAGLIONE

Maglione



CAPPELLO

Cappello

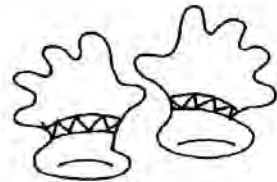

GUANTI

Guanti



CAPPOTTO

Cappotto



GIACCA

Giacca



VESTITO

Vestito



SCARPE

Scarpe

Nome _____ Classe _____ Data _____

I VESTITI

 Completa.



LA BAMBINA INDOSSA _____
E _____.

La bambina indossa
e



LA BAMBINA HA _____
E _____.

La bambina ha
e

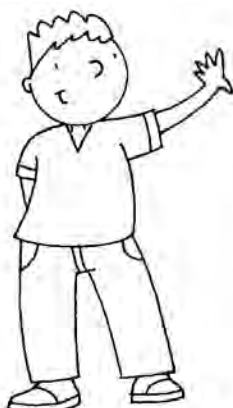

IL BAMBINO HA _____
E _____.

Il bambino ha
e



IL BAMBINO INDOSSA _____
E _____.

Il bambino indossa
e

Nome _____ Classe _____ Data _____

I CIBI



Leggi.



LATTE

Latte



CARNE

Carne

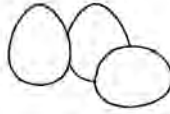

UOVA

Uova

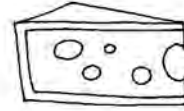

FORMAGGIO

Formaggio

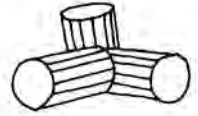

PASTA

Pasta

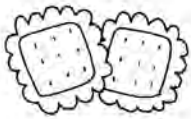

BISCOTTI

Biscotti

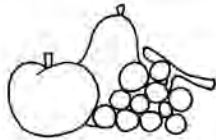

FRUTTA

Frutta

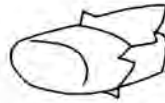

BURRO

Burro

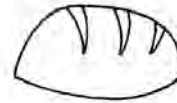

PANE

Pane



RISO

Riso



Dove vanno? Sistema i cibi nel frigorifero o nel mobiletto.

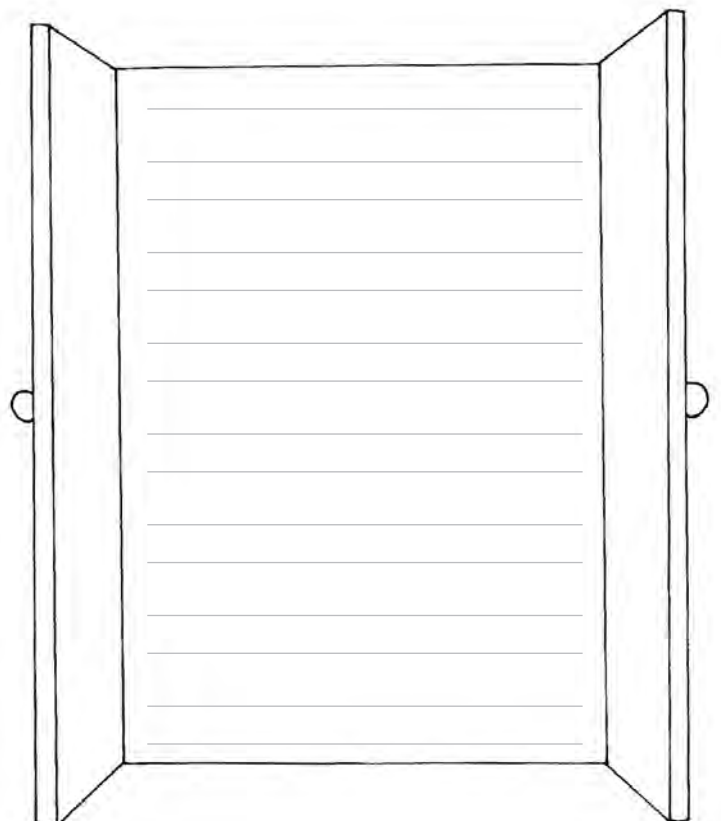
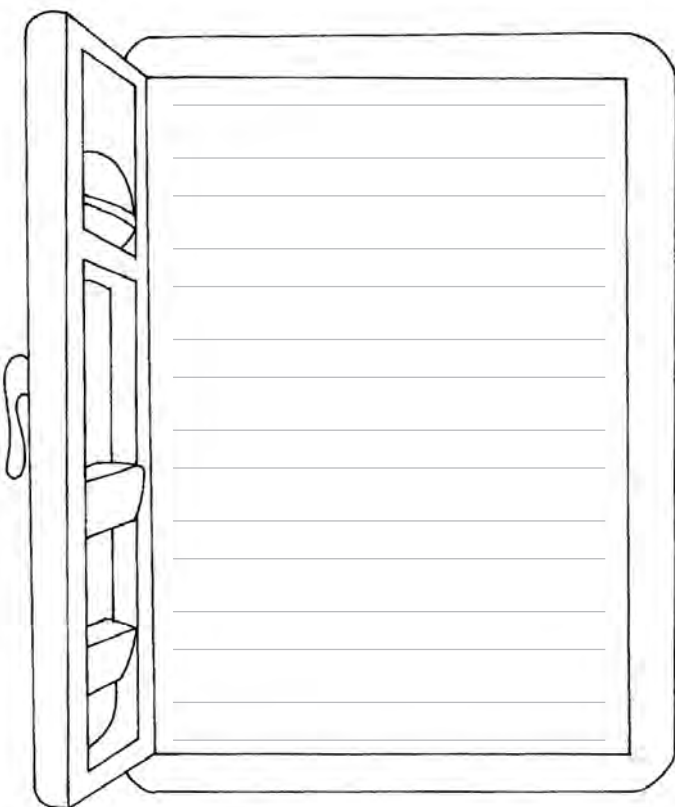

Nome _____ Classe _____ Data _____

IO IN CASA

 Leggi.



IO MANGIO LA PASTA.

Io mangio la pasta.



IO DORMO.

Io dormo



IO LAVO LE MANI.

Io lavo le mani.



IO LEGGO IL LIBRO.

Io leggo il libro.

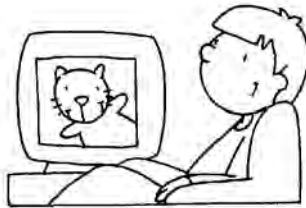

IO GUARDO LA TELEVISIONE.

Io guardo la televisione.

 Scrivi.





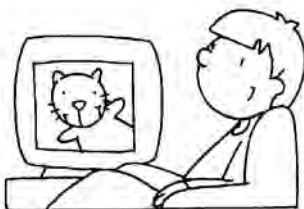



Nome _____ Classe _____ Data _____

I GIOCATTOLI

 Scrivi i nomi.

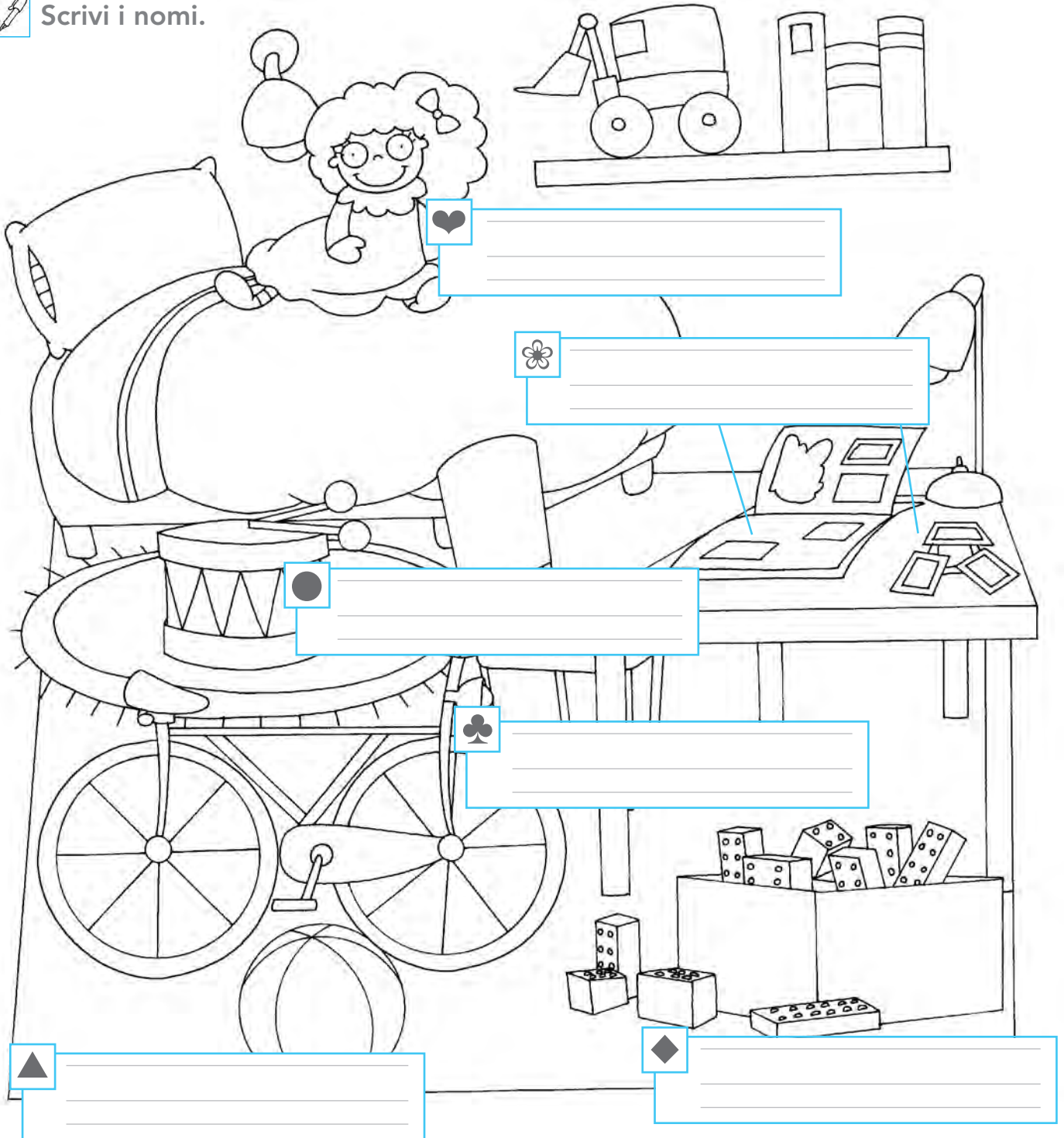

 Bicicletta

 Bambola

 Costruzioni

 Pallone

 Tamburo

 Figurine

Nome _____ Classe _____ Data _____

TU GIOCHI

 Completa.



TU TIRI LA _____

Tu tiri la _____



TU VESTI LA _____

Tu vesti la _____

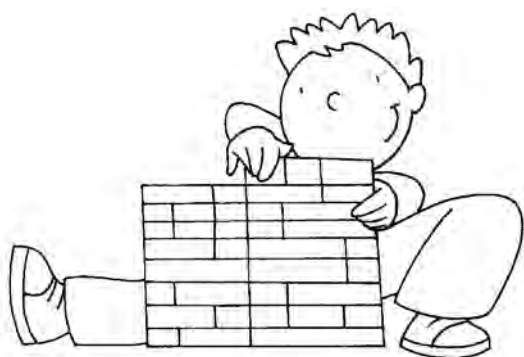

TU USI LE _____

Tu usi le _____



TU INCOLLI LE _____

Tu incolli le _____



TU SUONI IL _____

Tu suoni il _____



TU VAI IN _____





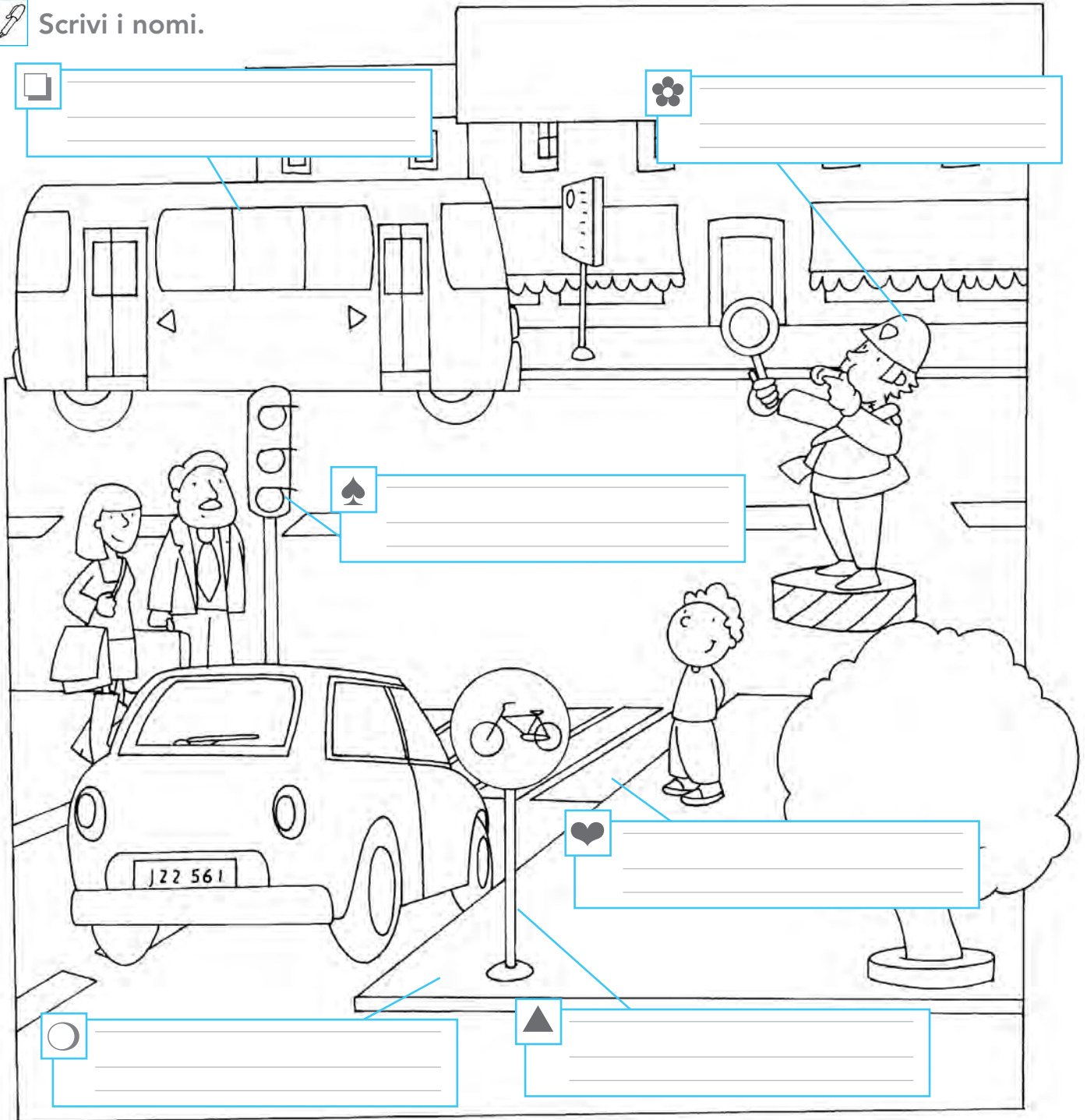

Tu vai in _____

Nome _____ Classe _____ Data _____

LA STRADA

 **Scrivi i nomi.**



- | | | |
|--|---|---|
|  <i>Semaforo</i> |  <i>Strisce pedonali</i> |  <i>Marcia piede</i> |
|  <i>Autobus</i> |  <i>Segnale stradale</i> |  <i>Vigile</i> |

Nome _____ Classe _____ Data _____

IN STRADA

 Completa.



LUCA ATTRAVERSA LA _____

Luca attraversa la

LI ZU CAMMINA SUL _____

Li Zu cammina sul

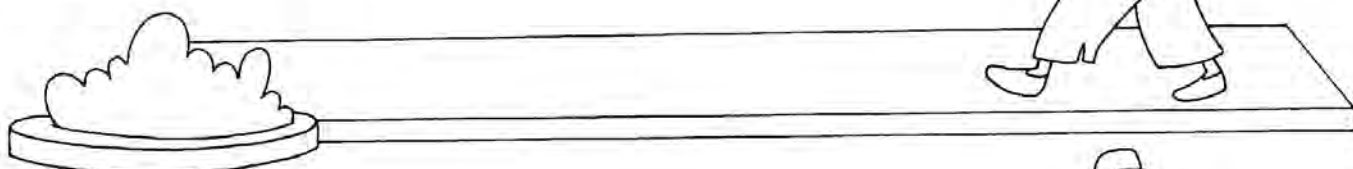

MADUSHI È FERMA AL _____

Madushi è ferma al

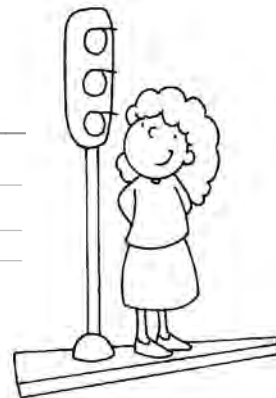

IL _____ FISCHIA.

Il _____ fischia.

L'AUTISTA GUIDA L' _____

L'autista guida l'

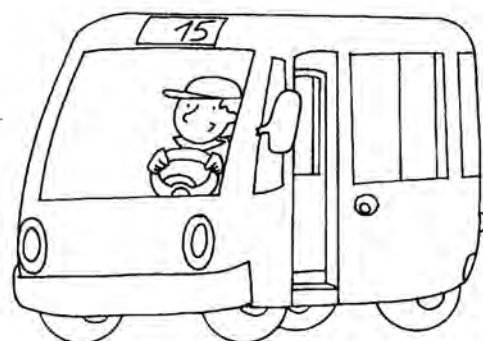

Nome _____ Classe _____ Data _____

I MEZZI DI TRASPORTO

♠ _____

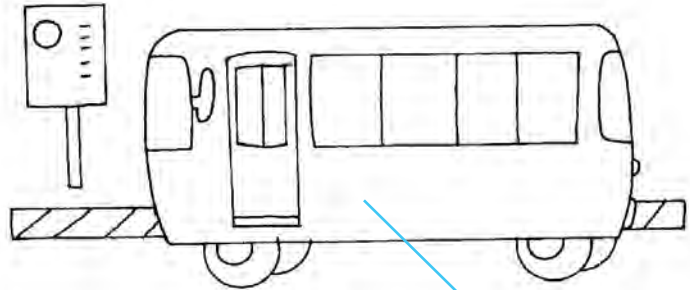
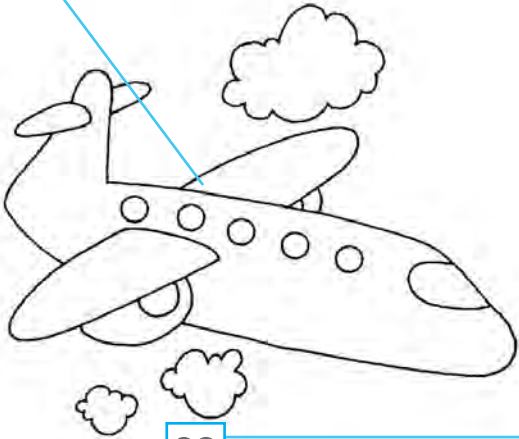

♣ _____

♥ _____

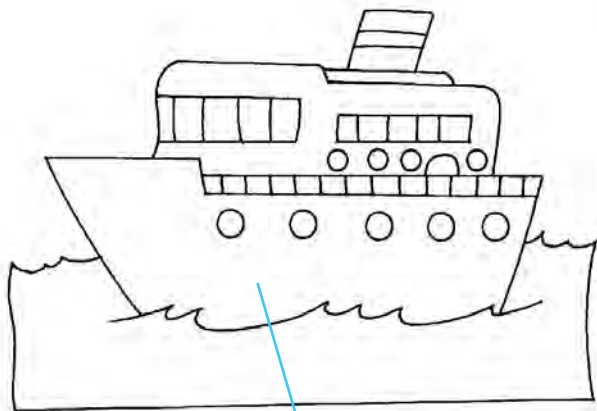
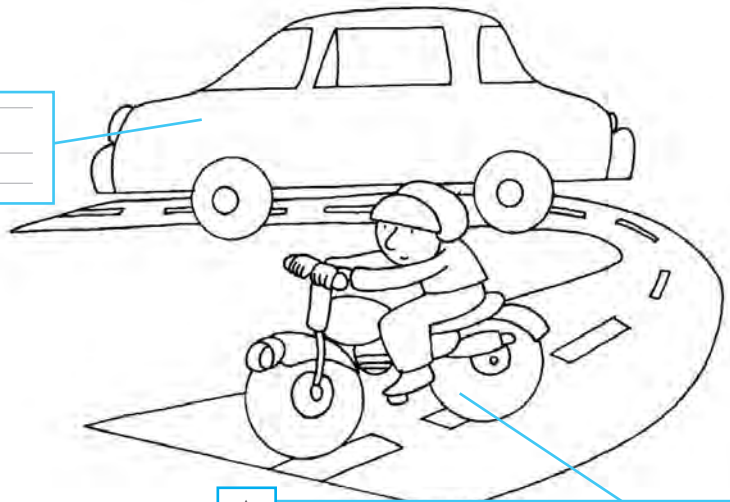

▲ _____

○ _____

★ _____

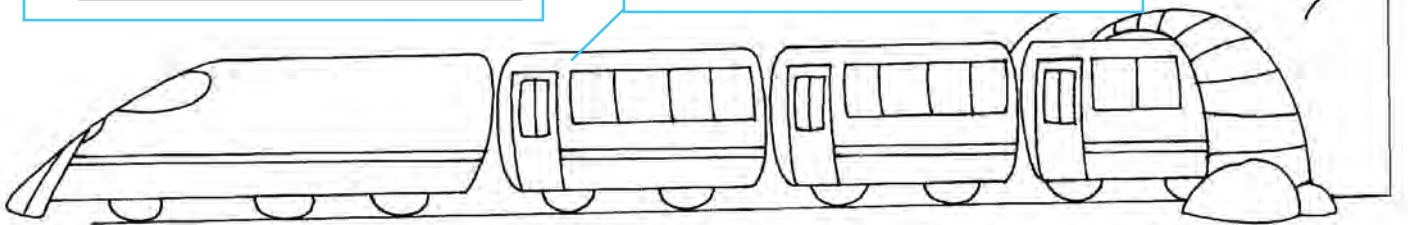

♠ Aereo

♥ Automobile

○ Nave

♣ Pullman

▲ Moto

★ Treno

Nome _____ Classe _____ Data _____

SUI MEZZI DI TRASPORTO

 Completa.

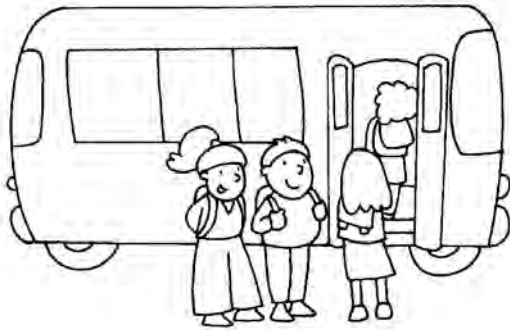

NOI SALIAMO SUL _____

Noi saliamo sul

NOI VIAGGIAMO IN _____

Noi viaggiamo in

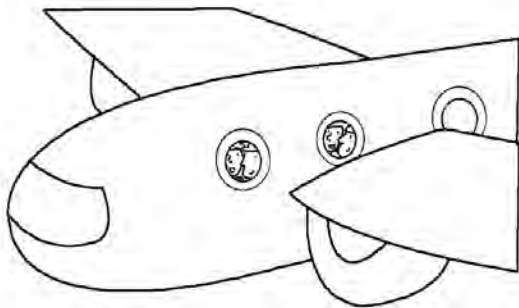

NOI VOLIAMO CON L' _____

Noi voliamo con l'

NOI PRENDIAMO LA _____

Noi prendiamo la

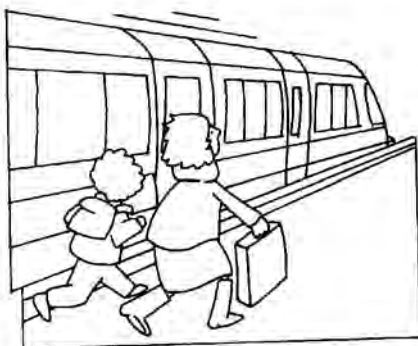
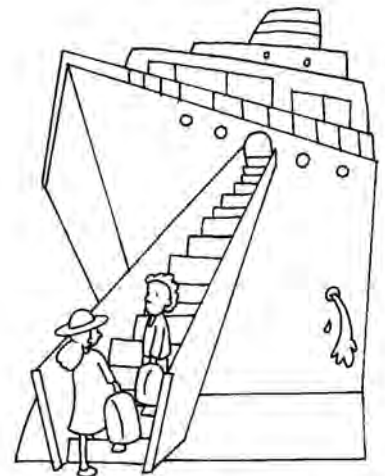

NOI ABBIAMO PERSO IL _____

Noi abbiamo perso il

Nome _____ Classe _____ Data _____

I NEGOZI

 **Scrivi i nomi.**

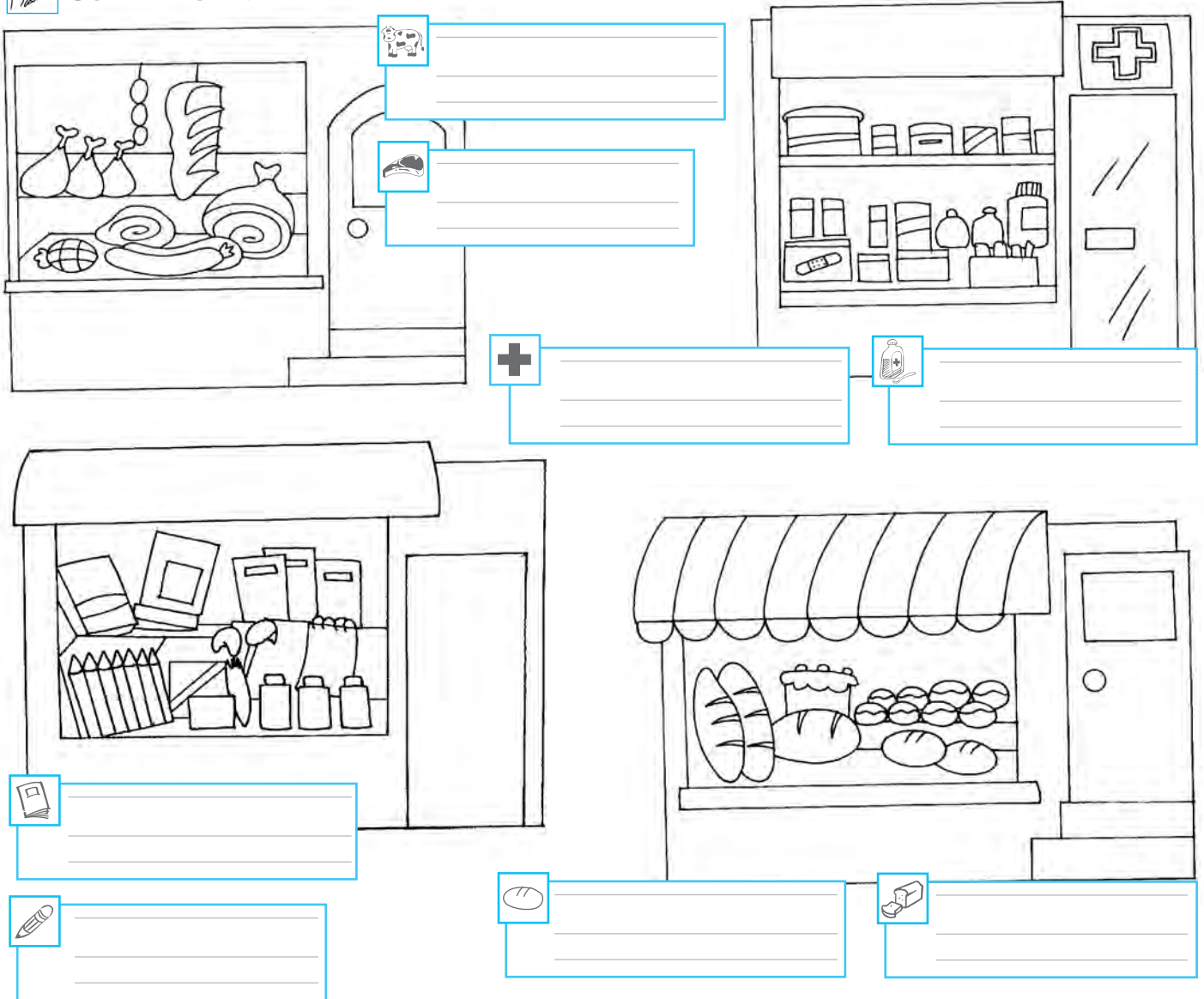

 Panetteria

 Farmacia

 Pane

 Medicine

 Cartoleria

 Macelleria

 Quaderni

 Carne



Nome _____ Classe _____ Data _____

NEI NEGOZI

 Completa.

VOI COMPERATE IL _____ IN _____

Voi comperate il _____ in _____



VOI COMPERATE LE _____

IN _____

Voi comperate le _____

in _____

VOI COMPERATE I _____

IN _____

Voi comperate i _____

in _____



Nome _____ Classe _____ Data _____

GLI ANIMALI

 **Scrivi i nomi.**

★ _____

● _____

♣ _____

⊕ _____

◆ _____

⊕ _____

■ _____

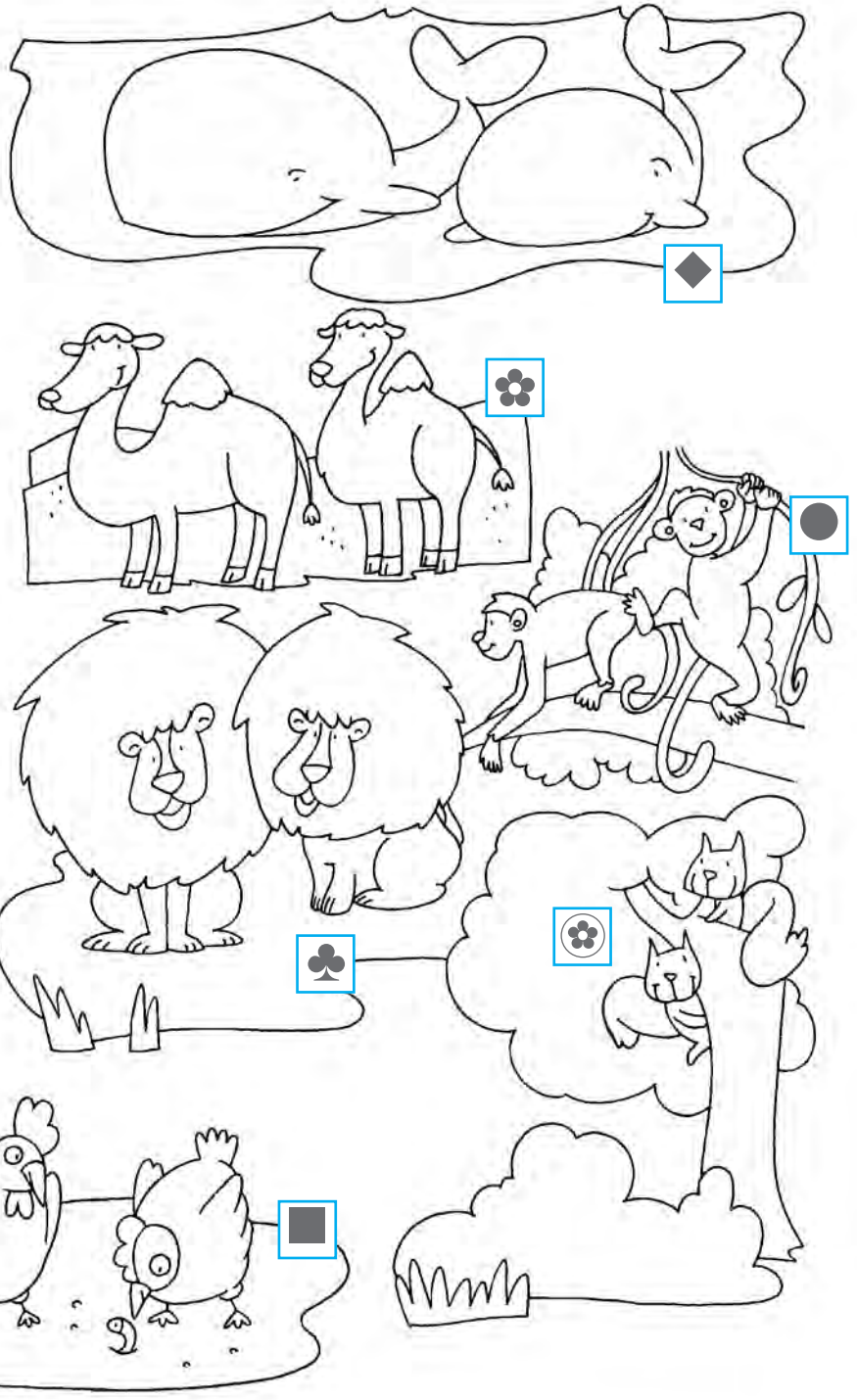

♣ Leoni ● Scimmie ◆ Balene ⊕ Scoiattoli

⊕ Dromedari ★ Rane ■ Galline

Nome _____ Classe _____ Data _____

CHE COSA MANGIANO GLI ANIMALI?

 Completa.

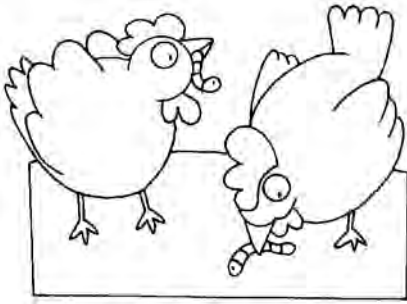

LE _____ MANGIANO I VERMI.

Le _____ mangiano i vermi.

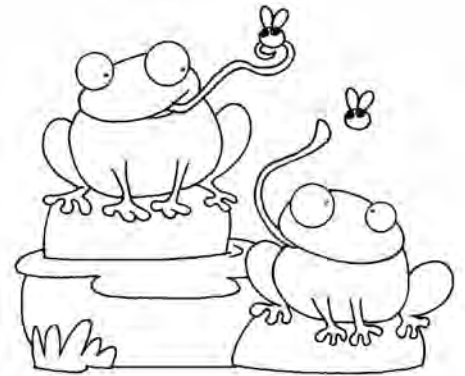

LE _____ MANGIANO GLI INSETTI.

Le _____ mangiano gli insetti.



GLI _____ MANGIANO LE NOCI

Gli _____ mangiano le noci



LE _____ MANGIANO LE BANANE.

Le _____ mangiano le banane.

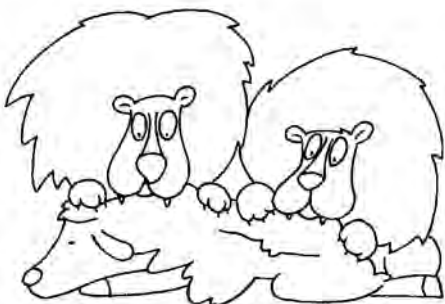

I _____ MANGIANO LA CARNE.

I _____ mangiano la carne.

Nome _____ Classe _____ Data _____

LE PARTI DEL CORPO

 Leggi.

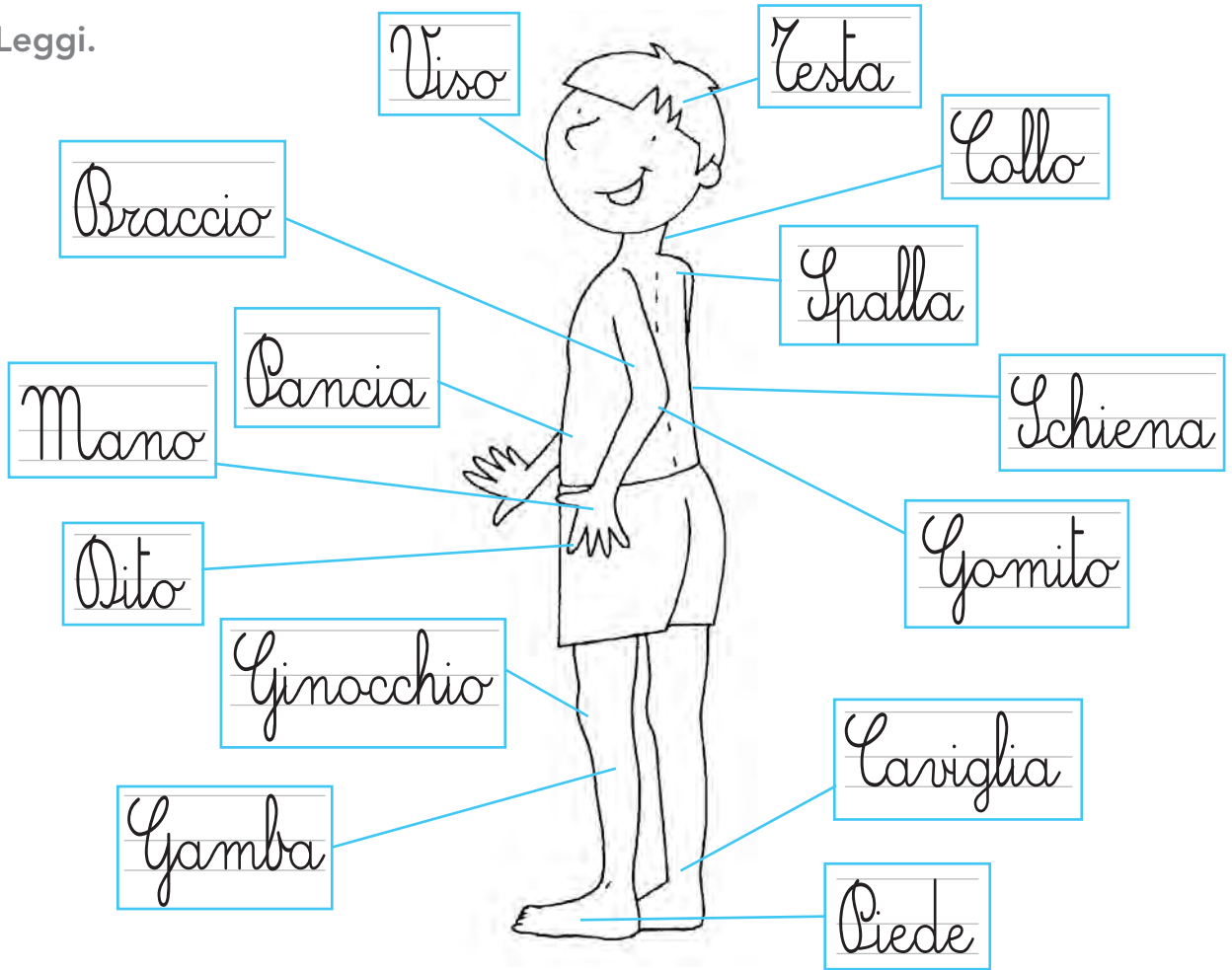

 Scrivi i nomi.





Nome _____ Classe _____ Data _____

CON IL CORPO FACCIAMO...

 Scrivi le frasi.









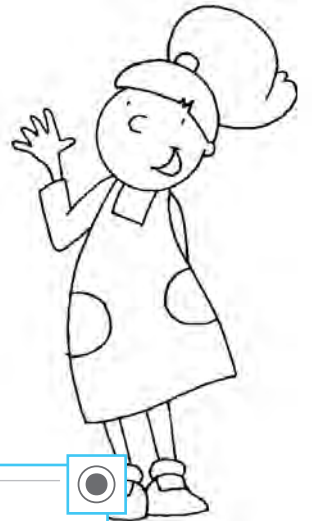











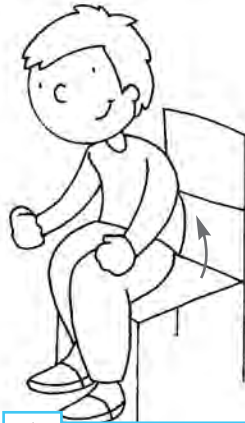







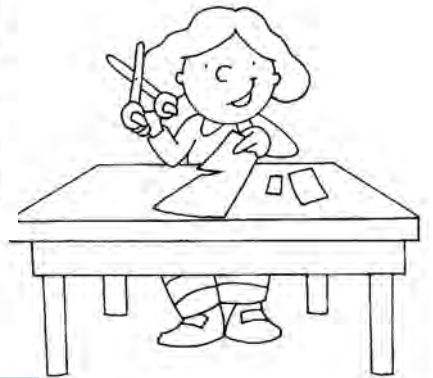







 Io salto.

 Io cammino.

 Io corro.

 Io taglio.

 Io scrivo.

 Io saluto.

 Io mi siedo.

 Io mi alzo.

Nome _____ Classe _____ Data _____

LE PARTI DEL VISO

 Leggi.

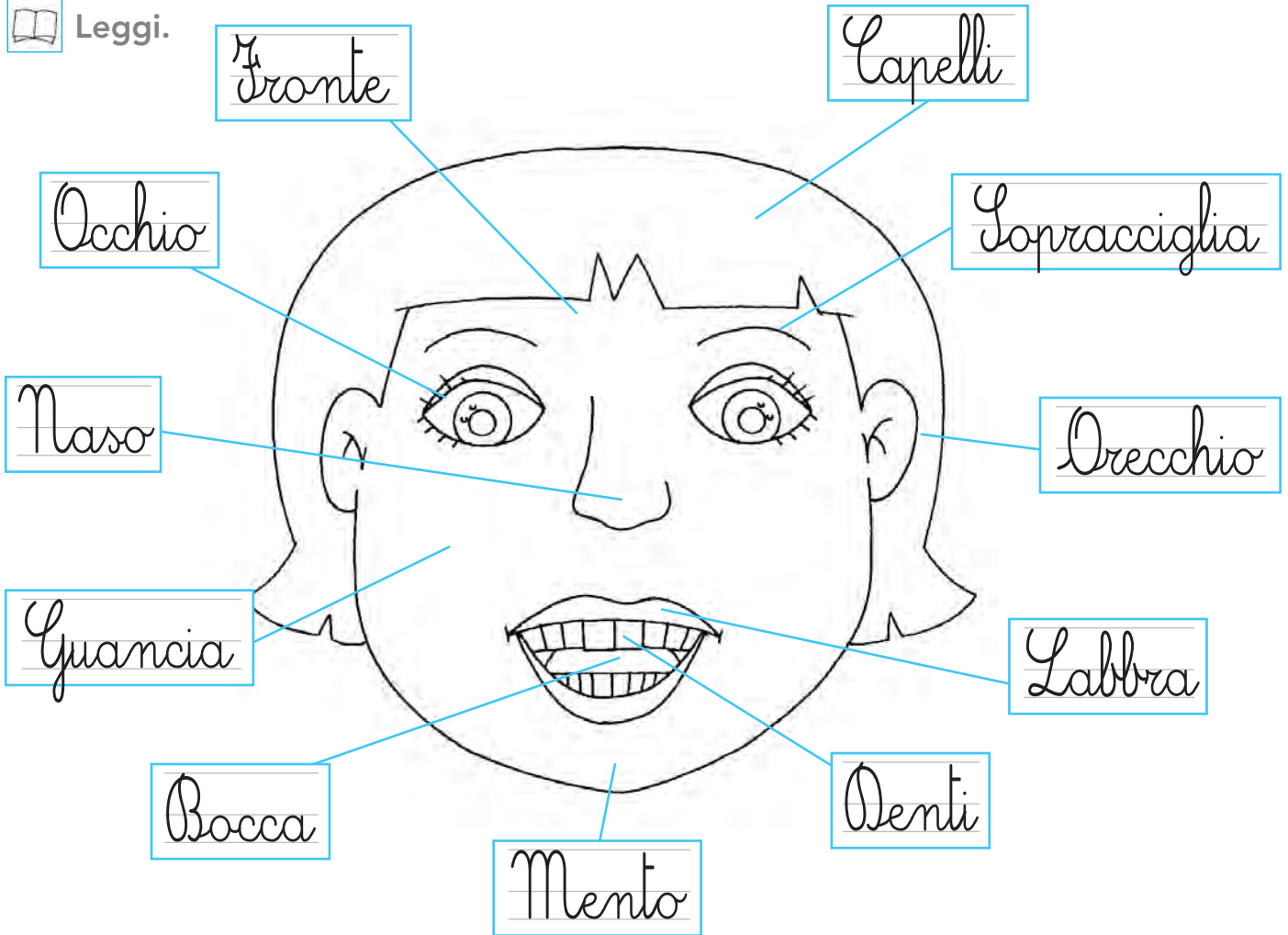

 Scrivi i nomi.



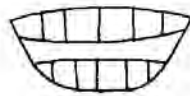

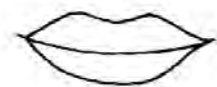



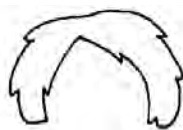



Nome _____ Classe _____ Data _____

CON IL VISO FACCIO...

 Scrivi le frasi.



 _____



 _____

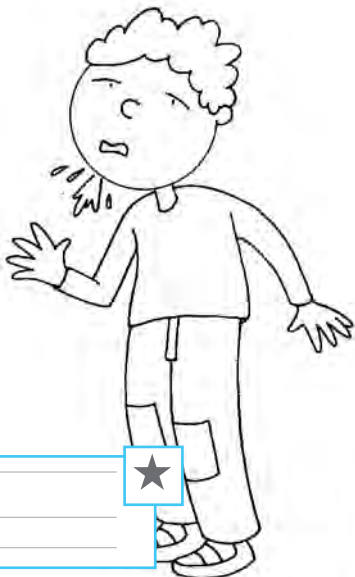

 _____

_____ 





 _____

_____ 



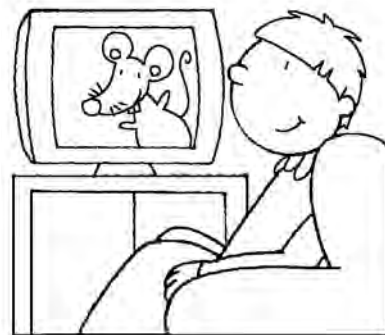

_____ 





_____ 

 Io sorrido.

 Io mangio.

 Io guardo.

 Io rido.

 Io parlo.

 Io starnutisco.

 Io mordo.

 Io piango.

Nome _____ Classe _____ Data _____

LE AZIONI DELLA GIORNATA



Leggi e completa.

MATTINA



DI _____ VADO A SCUOLA.

Di *vado a scuola.*

POMERIGGIO



DI _____ GIOCO.

Di *gioco.*

SERA



DI _____ GUARDO LA TELEVISIONE.

Di *guardo la televisione.*

NOTTE

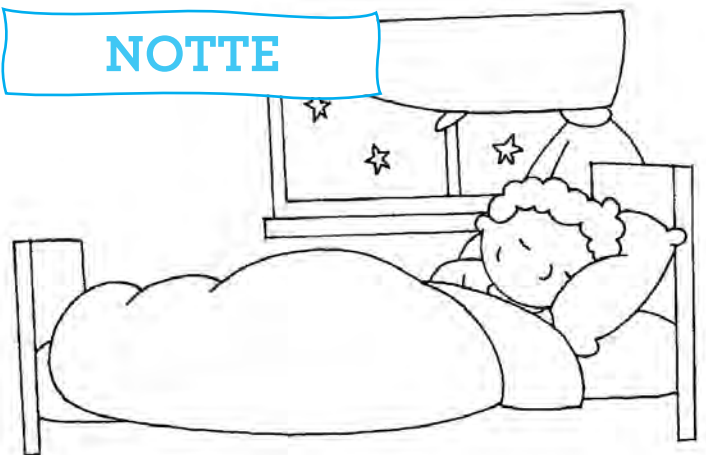

DI _____ DORMO.

Di *dormo.*

Nome _____ Classe _____ Data _____

LA SETTIMANA

  Leggi, poi completa.

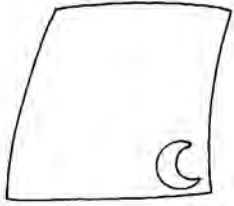

LUNEDÌ

Lunedì

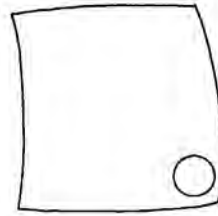

MARTEDÌ

Martedì

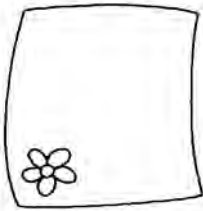

MERCOLEDÌ

Mercoledì

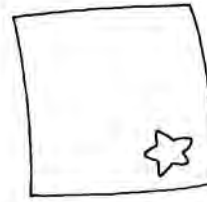

GIOVEDÌ

Giovedì

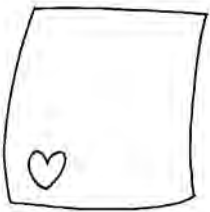

VENERDÌ

Venerdì

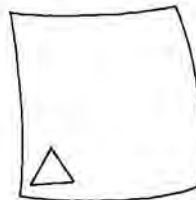

SABATO

Sabato

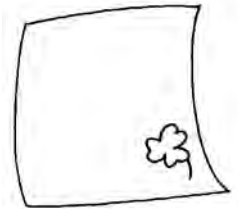

DOMENICA

Domenica

















Nome _____ Classe _____ Data _____

VERIFICA



Leggi e disegna.

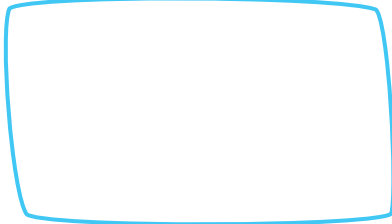

MANO

Mano



AEREO

Aereo

LIBRO

Libro



TAVOLO

Tavolo



LETTO

Letto



ZAINO

Zaino



PANE

Pane



FIORE

Fiore

LEONE

Leone



PALLA

Palla



MI AUTOVALUTO

Queste attività sono state: facili



abbastanza
facili



difficili



Leggere e scrivere

Questa sezione è dedicata all'apprendimento sistematico della letto-scrittura.

Ogni insegnante ha già sperimentato che l'apprendimento della letto-scrittura avviene in modo diverso da bambino a bambino. Se ciò è vero per i bambini che apprendono a leggere e a scrivere nella loro lingua madre, ancor di più lo è per i bambini per i quali l'italiano è la seconda lingua.

Pertanto dobbiamo tenere conto che alcune di queste schede potrebbero sembrare facili per qualche alunno o, viceversa, molto complesse per qualche altro, soprattutto per coloro che provengono da aree geografiche dove l'alfabeto è completamente diverso da quello italiano.

Una fase di analisi delle lettere è però fondamentale, sia che il bambino abbia già appreso la pronuncia e la scrittura di una serie di vocaboli italiani attraverso un apprendimento globale sia che non sia ancora in grado di discriminare alcun suono del nostro alfabeto.

L'approccio analitico alle varie lettere permette infatti al bambino di focalizzare la sua attenzione su un solo suono alla volta.

Aiutiamolo a pronunciare correttamente i suoni. Se dovesse avere difficoltà, potrà risultare molto utile fargli pronunciare i fonemi guardandosi in uno specchio, per osservare la posizione delle labbra e meglio memorizzarla.

Anche in questo lavoro è utile e proficuo coinvolgere, a rotazione, tutti i bambini del gruppo classe. Trasmettere le proprie conoscenze rafforza l'autostima degli alunni e aiuta la costruzione di rapporti positivi all'interno della classe.

I bambini stranieri spesso si mostrano nei confronti dell'insegnante molto timidi e timorosi di sbagliare. Imparare con l'aiuto di un coetaneo può risultare molto più rilassante e portare a migliori risultati.

In questa sezione vengono analizzate prima le vocali, poi le sillabe, infine le parole.

L'analisi delle parole (maschile/femminile – singolare/plurale) e la formazione della frase viene rimandata al successivo livello (monografia "Italiano per stranieri – 2° livello").

Nel testo non sono state scritte regole grammaticali (ad esempio quelle relative al suono SCI o al suono QU). Dovremo però far notare che QU/CU hanno due formule di scrittura, determinate dal fatto di essere seguite da vocale o da consonante.

La maggior parte delle schede può essere svolta individualmente dal bambino. Per un rafforzamento degli apprendimenti e una veloce memorizzazione, è però necessario che i suoni e le parole vengano scritti più volte anche sul quaderno.

Nelle ultime pagine sono state inserite le principali sillabe. Fotocopiamo tali pagine, plastifichiamole o attacchiamole su cartoncino, tagliamole e diamole al bambino affinché si eserciti nella composizione di parole.

Nome _____ Classe _____ Data _____

LA VOCALE A



Copia la vocale A.

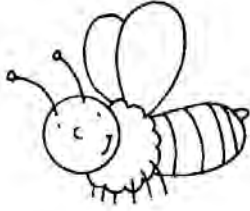

A a _____

A a _____



Colora solo le A.

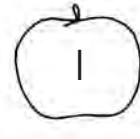
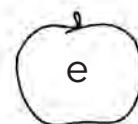

Inserisci la vocale A.



__EREO

__ereo

ereo

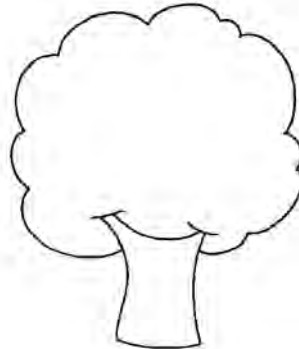

__LBERO

__lbero

lbero

__N__N__S

__n__n__s

n n s

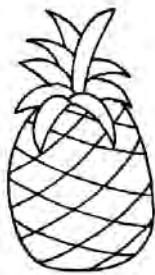

B__N__N__

b__n__n__

B n n

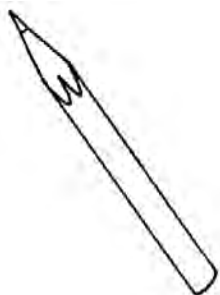

M__TIT__

m__tit__

M tit

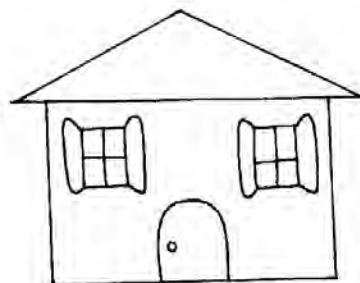

C__S__

c__s__

C s

Nome _____ Classe _____ Data _____

LA VOCALE E

 Copia la vocale E.

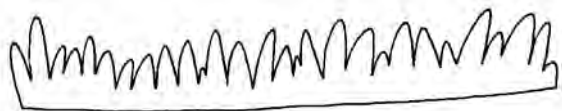

E e _____

E e

 Colora solo le E.

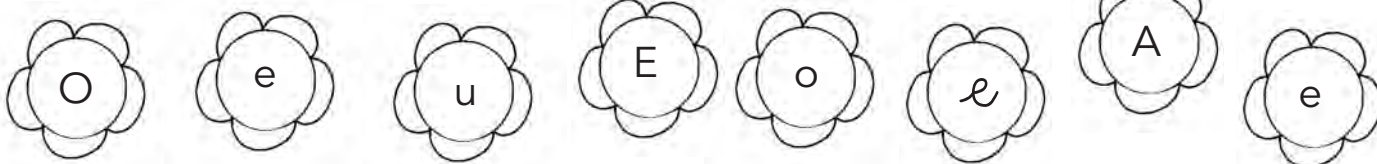

 Inserisci la vocale E.

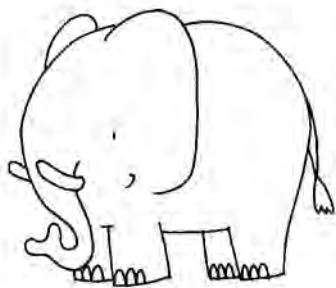

_L_FANT_

_l_fant_

l fant



PI_D_

pi_d_

Pi d

T_L_FONO

t_l_fono

t l fono

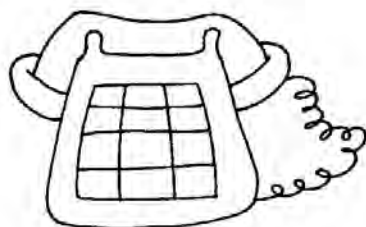

_D_RA

_d_ra

d ra

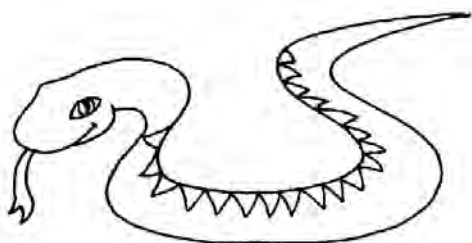

S_RP_NT_

s_rp_nt_

S rp nt

D_NT_

d_nt_

D nt



Nome _____ Classe _____ Data _____

LA VOCALE I

 Copia la vocale I.



I i
I i

 Colora solo le I.

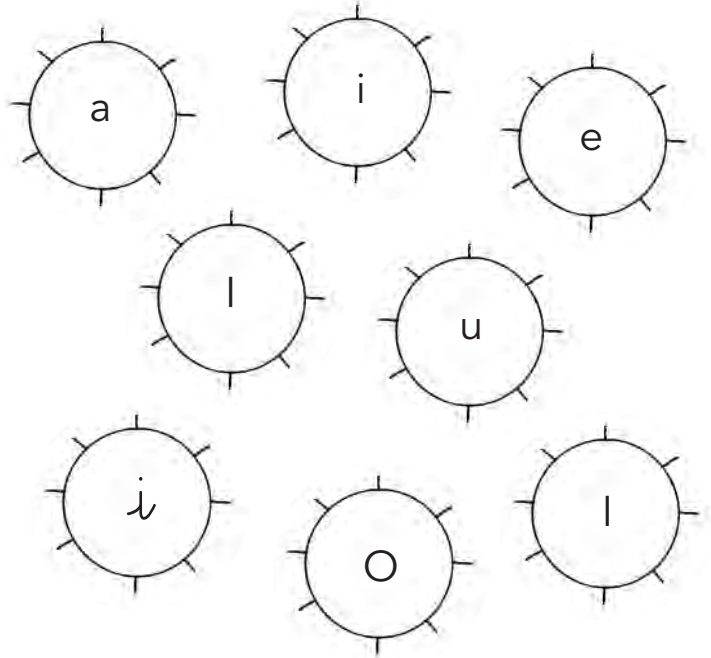

 Inserisci la vocale I.

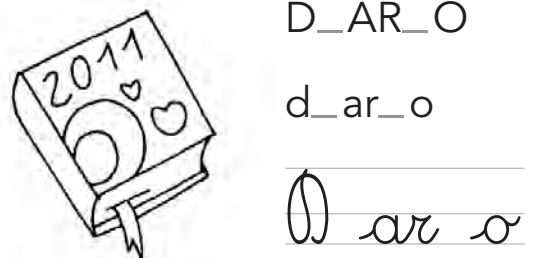
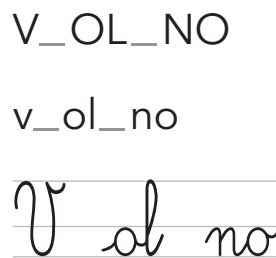
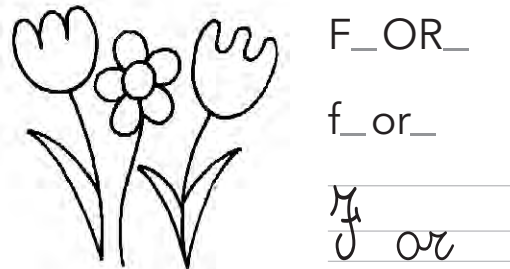
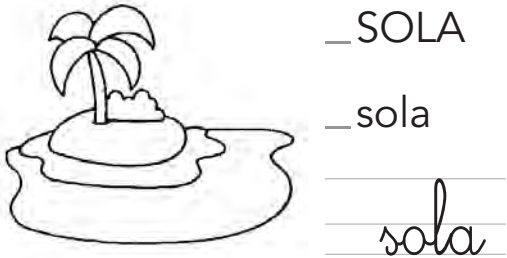

Nome _____ Classe _____ Data _____

LA VOCALE O

 Copia la vocale O.

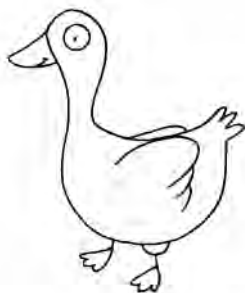

O o _____
O o _____

 Colora solo le O.

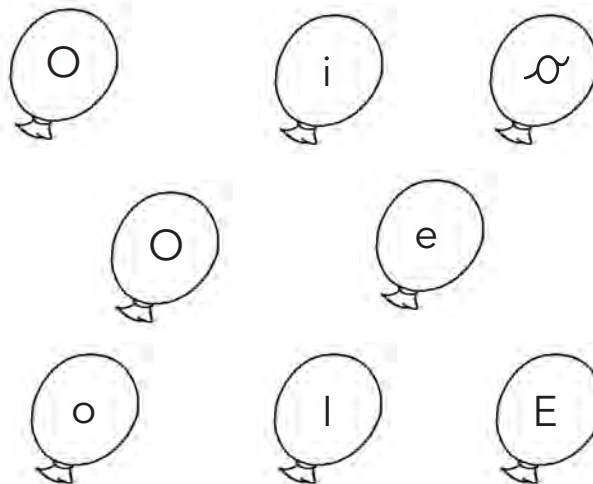

  Inserisci la vocale O.



__RS__
 __rs__

rs



__MBRELL__
 __mbrell__

mbrell

T_P_

t_p_

t p



__R_L_GI__

__r_l_gi__

r l gi



P_M_D_R_

p_m_d_r_

P m d r

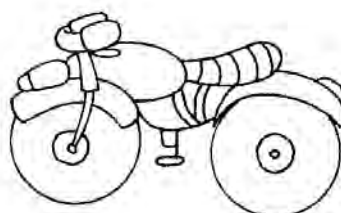

M_T_

m_t_

M t

Nome _____ Classe _____ Data _____

LA VOCALE U



Copia la vocale U.

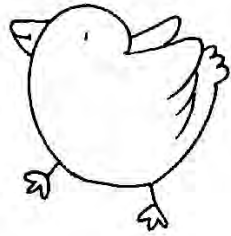

U u _____

U u _____



Colora solo le U.

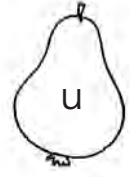
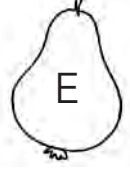

Inserisci la vocale U.

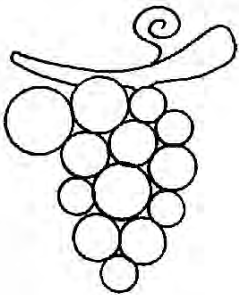

_VA

_va

va

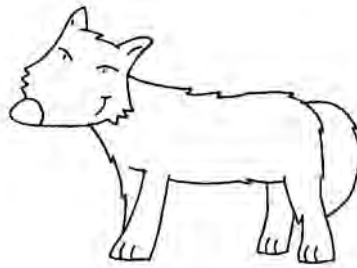

L_PO

L_po

L po

R_OT A

r_ota

R ota

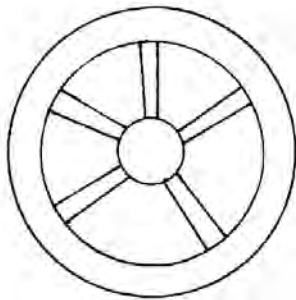

G_FO

g_fo

G fo



N_VOLA

n_vola

N vola

_OVO

_ovo

ovo

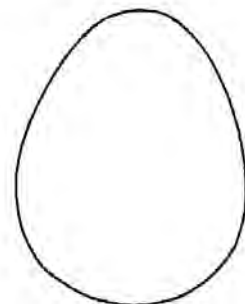

Nome _____ Classe _____ Data _____

LE VOCALI

 Scrivi la vocale iniziale.

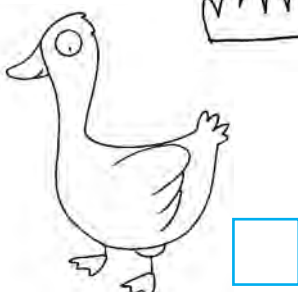
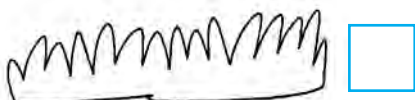
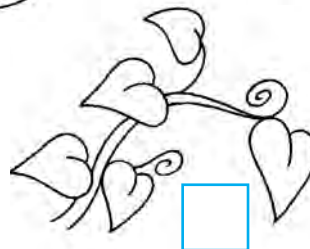
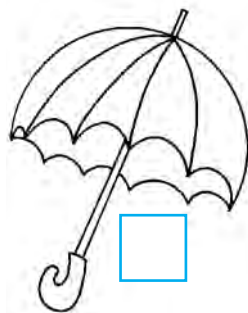
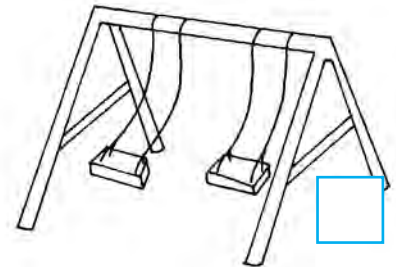
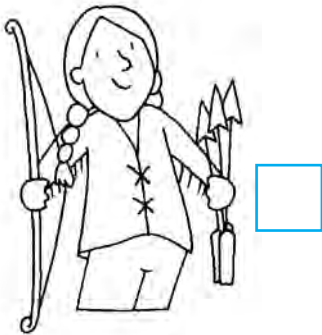
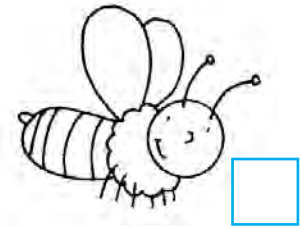
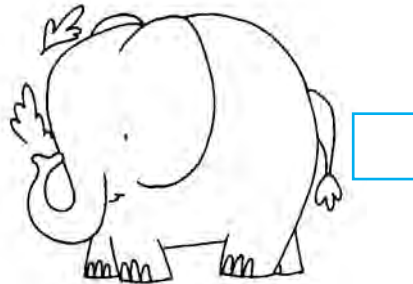
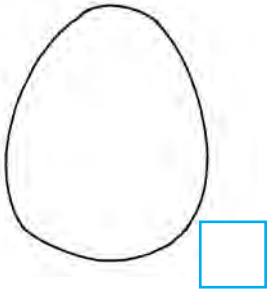
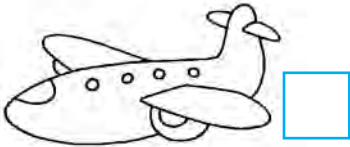

Nome _____ Classe _____ Data _____

LA CONSONANTE P

 Copia la consonante P.

P p _____

P p _____

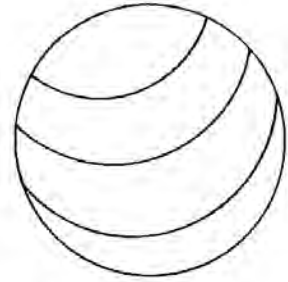

 Inserisci la P.



_E_ERONE

_e_erone

e erone



_IRATA

_irata

irata



SCAR_A

scar_a

Scar a



_A_ERA

_a_era

a era

 Forma le sillabe.

P	A → PA	pa	<i>pa</i>
	E →	_____	_____
	I →	_____	_____
	O →	_____	_____
	U →	_____	_____



___NE ___ne _____ *ne*



___RA ___ra _____ *ra*



___PA ___pa _____ *pa*



___MODORO
___modoro _____ *modoro*



___MA ___ma _____ *ma*

 Circonda le sillabe PA - PE - PI - PO.



PECORA

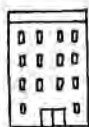

PALAZZO



PINO



LAMPO

Nome _____ Classe _____ Data _____

LA CONSONANTE L

 Copia la consonante L.



L l _____

L l _____

 Inserisci la L.



__UCERTO__A

__ucerto__a

ucerto a



__UMACA

__umaca

umaca

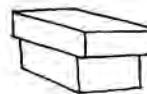

SCATO__A

scato__a

Scato a



__IMONE

__imone

imone

 Forma le sillabe.

A → LA la la
 E → _____
 L → I → _____
 O → _____
 U → _____

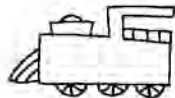

 Inserisci le sillabe.

__NA _____ na

__ONE __one one

__BRO __bro bro

__COMOTIVA comotiva

__NA __na na

 Scrivi.



Nome _____ Classe _____ Data _____

LA CONSONANTE R

 Copia la consonante R.

R r _____

R r _____



 Inserisci la R.

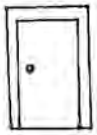

PO_TA

po_ta

po ta

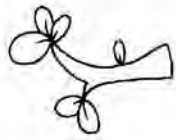

_AMO

_amo

amo



SI_ENA

si_ena

Si ena

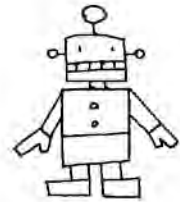

_OBOT

_obot

obot

 Forma le sillabe.

R → A → _____
 R → E → _____
 R → I → _____
 R → O → _____
 R → U → _____

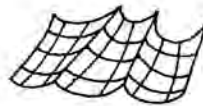

 Inserisci le sillabe.

___GNO _____
 ___gno *gno*
 ___TE ___te _____
 ___te *te*
 ___SO ___so _____
 ___so *so*
 ___SA ___sa _____
 ___sa *sa*
 ___OTA ___ota _____
 ___ota *ota*

 Completa.

IL _____ MANGIA LA _____



Nome _____ Classe _____ Data _____

LA CONSONANTE M

 Copia la consonante M.

M m _____

M m _____



 Inserisci la M.



_EDUSA

_edusa

edusa



A_BULANZA

a_bulanza

A bulanza



_ANIGLIA

_aniglia

aniglia



_A__A

_a__a

a a

 Forma le sillabe.

M

- A → _____
- E → _____
- I → _____
- O → _____
- U → _____

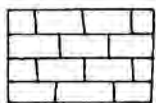

 Inserisci le sillabe.

___NO ___no no

___LA ___la la

___ELE ___ele ele

___TO ___to to

___RO ___ro ro

 Scrivi.

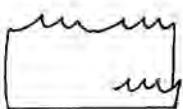

Nome _____ Classe _____ Data _____

LA CONSONANTE T

 Copia la consonante T.



T t _____
 T t _____

 Forma le sillabe.

T
 A → _____
 E → _____
 I → _____
 O → _____
 U → _____

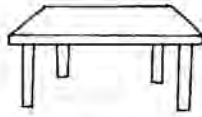

 Inserisci le sillabe.

___ VOLO _____ volo
 ___ volo _____
 ___ STA ___ sta _____ sta
 ___ GRE ___ gre _____ gre
 ___ RO ___ ro _____ ro
 ___ LIPANO _____ lipano
 ___ lipano _____

 Scrivi.

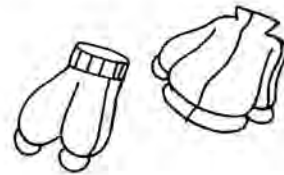
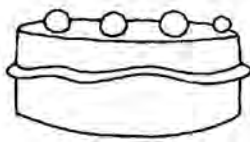

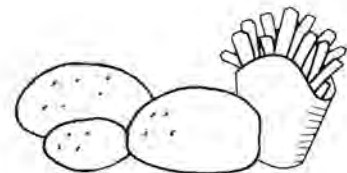
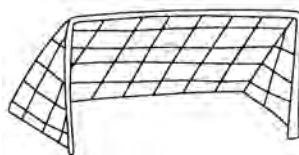
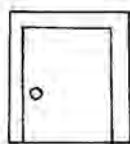

Nome _____ Classe _____ Data _____

LA CONSONANTE N

 Copia la consonante N.

N n _____

N n _____

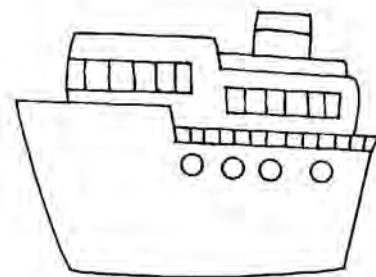

 Forma le sillabe.

N	A →	_____	_____
	E →	_____	_____
	I →	_____	_____
	O →	_____	_____
	U →	_____	_____



 Inserisci le sillabe.

___SO	___so	so
___VE	___ve	ve
___DO	___do	do
___DO	___do	do
___VOLA	___vola	vola

 Inserisci NO o ON, NI o IN.

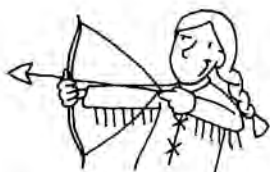

diano



do



da



ce

  Leggi e disegna.

MORE E LAMPONI NEL PRATO



Nome _____ Classe _____ Data _____

LA CONSONANTE B

 Copia la consonante B.

B b _____

B b _____



 Forma le sillabe.

Diagram showing the letter B branching into vowels A, E, I, O, U. Each branch leads to a set of three horizontal lines for writing practice.

A → _____
E → _____
I → _____
O → _____
U → _____

 Forma le sillabe inverse.

Diagram showing the letter B with arrows pointing to vowels A, E, I, O, U. Each branch leads to a set of three horizontal lines for writing practice. The first branch (B-A) is pre-filled with 'AB' and 'ab', and the cursive 'ab' is written on the top line.

A → AB ab *ab*
E → EB _____
I → IB _____
O → OB _____
U → UB _____

 Inserisci la sillaba mancante.

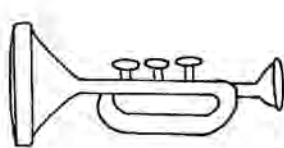

_____ fana _____

_____ trom _____

_____ tam ro _____

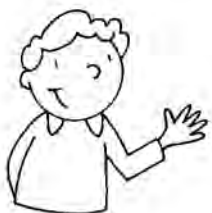
_____ dino _____

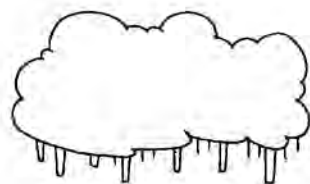
_____ Bam no _____

_____ sco _____

Nome _____ Classe _____ Data _____

LA CONSONANTE S

 Copia la consonante S.



S s _____
 s s _____

 Forma le sillabe.

S → A → _____
 S → E → _____
 S → I → _____
 S → O → _____
 S → U → _____

 Forma le sillabe inverse.

A → AS as *as*
 E → ES _____
 I → IS _____
 O → OS _____
 U → US _____

 Con le sillabe forma e scrivi le parole.

 ne sa po

 la so i

  Leggi e disegna.

IL SERPENTE SUONA LA TROMBA



Nome _____ Classe _____ Data _____

LA CONSONANTE F

 Copia la consonante **F**.

F f _____

F f _____

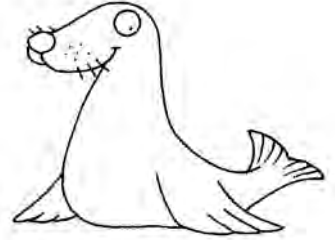

 Forma le sillabe.

F

- A → _____
- E → _____
- I → _____
- O → _____
- U → _____

 Forma le sillabe inverse.

F

- AF af *af*
- E → _____
- EF _____
- I ← _____
- O → _____
- U → _____

 Scrivi.

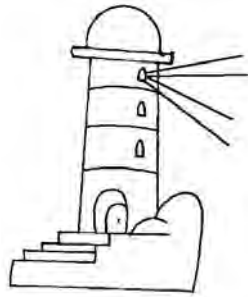

 Con le sillabe forma e scrivi le parole.



fal far la

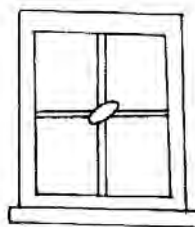
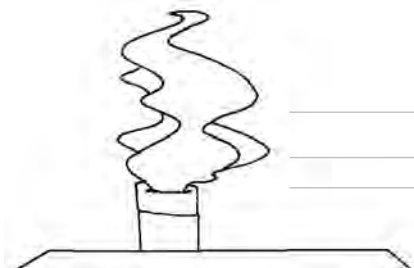

stra fi ne

Nome _____ Classe _____ Data _____

LA CONSONANTE D

 Copia la consonante D.

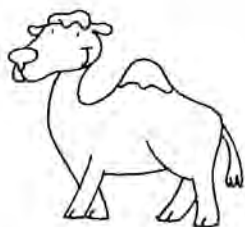

D d _____

D d _____

 Forma le sillabe.

 Forma le sillabe inverse.

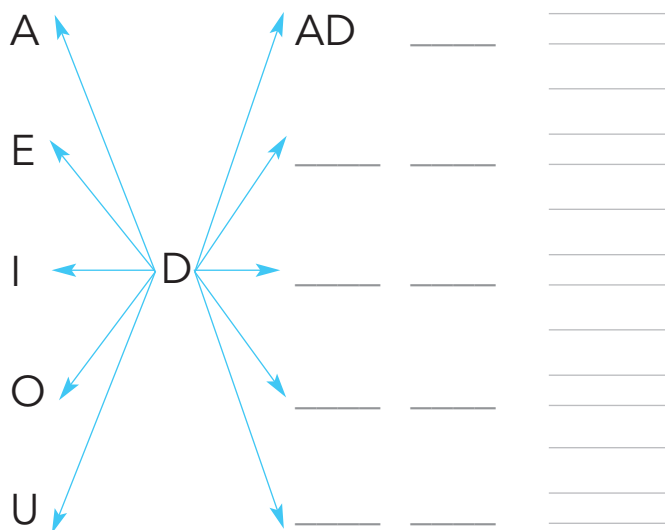
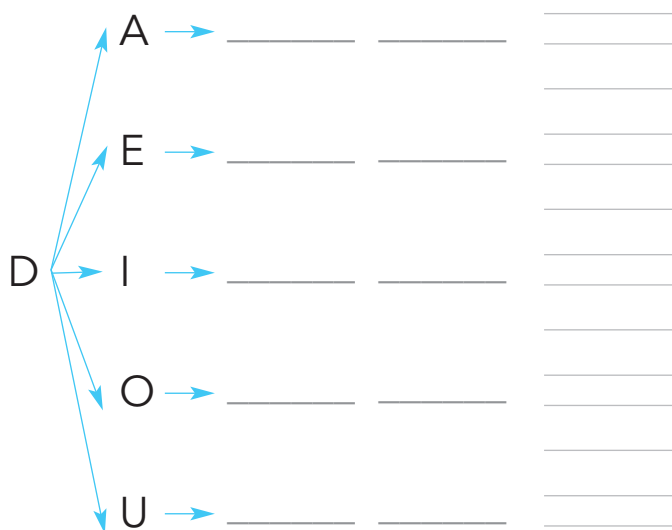

 Scrivi.

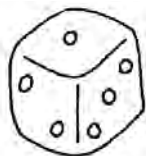





 Con le sillabe forma e scrivi le parole.

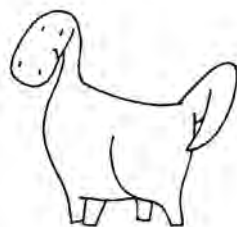

di sau no ro

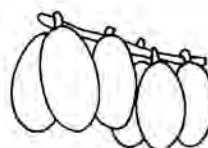











dat ri te

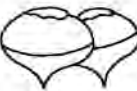

Nome _____ Classe _____ Data _____

GIOCA CON LE SILLABE

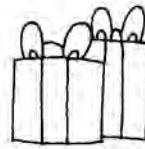
 Cambia l'ordine delle sillabe e scrivi le parole.

	MO RE	_____		DO NO	_____
	RE	_____			_____
	RA PE	_____		RA MO	_____
		_____			_____
	LA ME	_____		NI DO	_____
		_____			_____

 Colora le sillabe giuste.

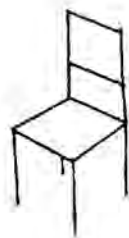
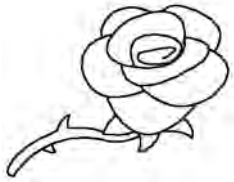
OR	→	SO		SO	→	SO	
RO	→			OS	→		
ES	→	DIA		RO	→	SA	
SE	→			OR	→		

Nome _____ Classe _____ Data _____

LA CONSONANTE V

 Copia la consonante V.

V v _____

V v _____

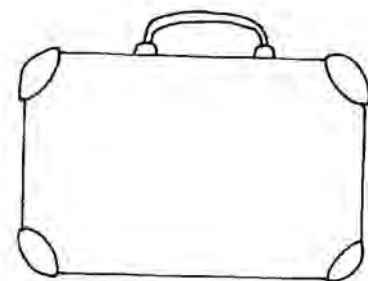

 Forma le sillabe.

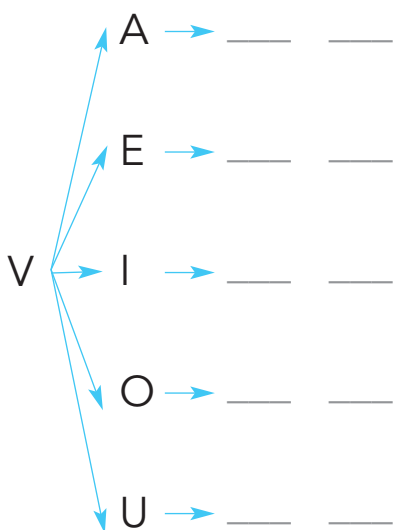

 Con le sillabe forma e scrivi le parole.

	va	u	_____	
	ve	ne	_____	
	vo	la	nu	_____
	vi	na	_____	

 Collega ogni parola al disegno.

vulcano vela
 vaso televisione

  Ricomponi la frase e disegna.

LA VESPA VASO
 SUL VOLA

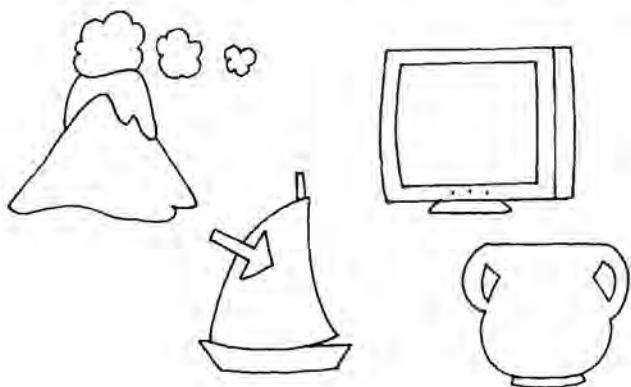

Nome _____ Classe _____ Data _____

LA CONSONANTE Z

 Copia la consonante Z.

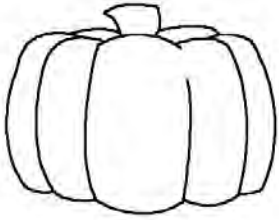

Z z _____

Z z _____

 Forma le sillabe.

Z

- A → _____
- E → _____
- I → _____
- O → _____
- U → _____

 Scrivi le parole e collegale al disegno.

zzoop _____

zerab _____

iozan _____



 Collega ogni parola al disegno.

zampa

tazza

pizza



  Ricomponi la frase e disegnalà.

ALLA ZEBRA

FA

LA ZANZARA

I DISPETTI



Nome _____ Classe _____ Data _____

LE CONSONANTI H J K W X Y

  Leggi e copia.

H h _____

H h

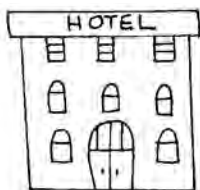

HOTEL hotel

Hotel

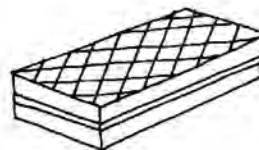

W w _____

W w

WAFER wafer

Wafer

J j _____

J j



JEANS jeans

Jeans



X x _____

X x

TAXI taxi

Taxi

K k _____

K k



KOALA koala

Koala



Y y _____

Y y

YOGURT yogurt

Yogurt

 Copia la parola.

IO MANGIO IL _____



WURSTEL

Nome _____ Classe _____ Data _____

VERIFICA

 Completa.

MA  _____

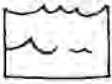
MA  _____

NE  _____

NE  _____

NA  _____

NA  _____

MO  _____

MO  _____







TO  _____

TO  _____

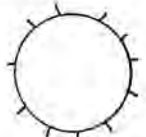
BA  _____

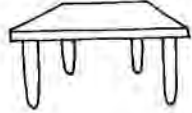
BA  _____

 Scrivi.

			
_____	_____	_____	_____
_____	_____	_____	_____
			
_____	_____	_____	_____
_____	_____	_____	_____

MI AUTOVALUTO

Queste attività sono state:

facili



abbastanza
facili



difficili



Nome _____ Classe _____ Data _____

LA CONSONANTE C: SUONI DURI

 Copia la consonante C.



C c _____

C c _____

 Forma le sillabe.

C → A → CA ca *ca*

C → HE → CHE _____

C → HI → CHI _____

C → O → CO _____

C → U → CU _____

 Leggi.

- | | |
|--------|--------|
| CHIAVE | CASA |
| FOCHE | LUMACA |
| CAMINO | CUCINA |

 Scrivi.

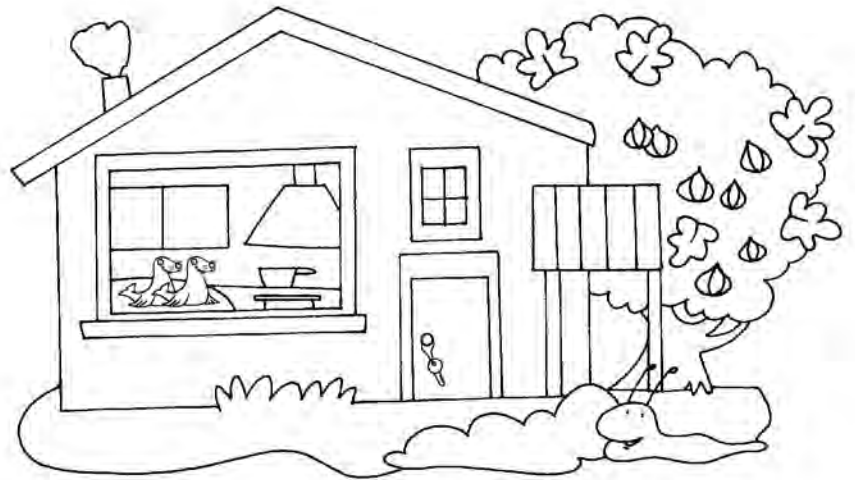
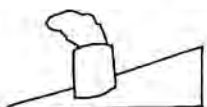
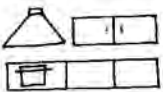

 Completa inserendo CA - CO - CU - CHI - CHE.



Ca _____

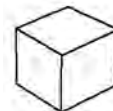

bo _____



Bra _____



Bra _____



Muc _____



Muc _____

Nome _____ Classe _____ Data _____

LA CONSONANTE C: SUONI DOLCI

 Forma le sillabe.

C				
IA	E	I	IO	IU
↓	↓	↓	↓	↓
CIA	CE	CI	CIO	CIU
cia	_____	_____	_____	_____
_____	_____	_____	_____	_____
cia	_____	_____	_____	_____

 Leggi.

CIUCCIO
CIVETTA
MICIO

CESTINO
CEROTTO
ARANCIA

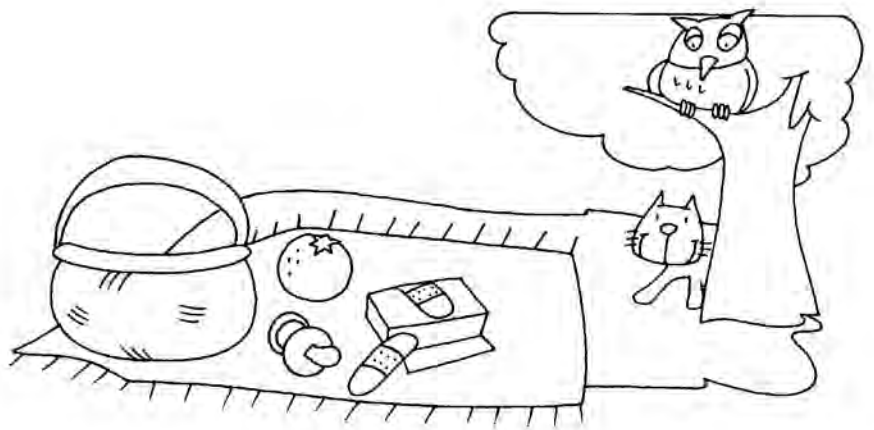

 Scrivi.













 Completa inserendo **CI - CE - CIA - CIO - CIU**.



Cami

ndolo



No

No



flo

Nome _____ Classe _____ Data _____

LA CONSONANTE G: SUONI DURI

 Copia la consonante G.



G g _____

G g

 Forma le sillabe.





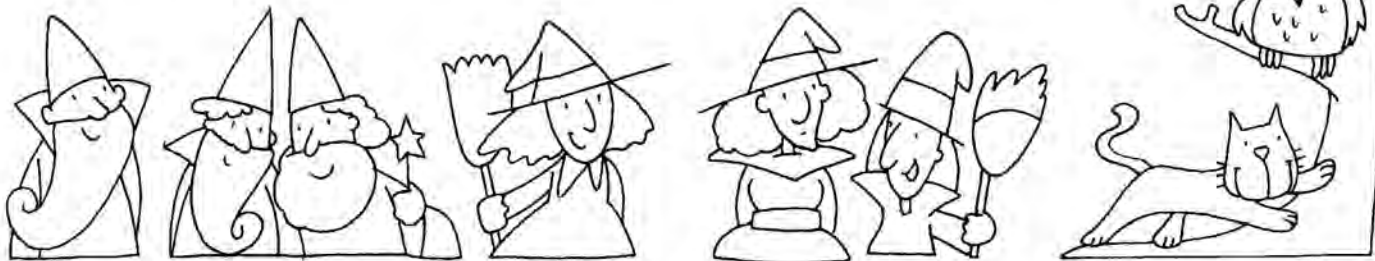

G	↗	A	→	GA	ga	<i>ga</i>
	↗	HE	→	GHE	_____	_____
	→	HI	→	GHI	_____	_____
	↘	O	→	GO	_____	_____
	↘	U	→	GU	_____	_____

 Leggi.

MAGO MAGHI STREGA STREGHE GUFO GATTO



 Scrivi.

	_____
	_____
	_____
	_____
	_____
	_____

 Completa inserendo GA - GO - GU - GHE - GHI.

	<i>Mung</i>		<i>Al</i>
	<i>fo</i>		<i>Mung</i>
	<i>Tartaru</i>		
	<i>Tartaru</i>		
	<i>Ora</i>		<i>Ora</i>

Nome _____ Classe _____ Data _____

LA CONSONANTE **G**: SUONI DOLCI

 **Forma le sillabe.**

G







IA E I IO IU
 ↓ ↓ ↓ ↓ ↓
 GIA GE GI GIO GIU
 _____ _____ _____ _____ _____
 _____ _____ _____ _____ _____
gia _____ _____ _____ _____

 **Leggi.**

GIOCATTOLI GELATO GIOSTRA
GIUBBOTTO GIACCA GIRAFFA





 **Scrivi.**

 _____
 _____
 _____
 _____
 _____
 _____

 **Completa.**

 È il colore _____
del sole: _____

 È il colore del _____
cielo nuvoloso: _____

 Lo indossi _____
di notte: _____

 Cade dalle _____
nuvole: _____

Nome _____ Classe _____ Data _____

CHE – CHI – GHE – GHI

  Leggi e copia al posto giusto.

 Chiave  Unghia  Maghi  Righello

 Archi  Mucche  Ghiacciolo  Barche

 Ghepardo  Occhio  Chele  Spaghetti

 Zucche  Panchina  Ghiande  Spighe

CHE

Blank writing area for the 'CHE' category, featuring a ruler icon at the top and several horizontal lines for text.

CHI

Blank writing area for the 'CHI' category, featuring a chair icon at the top and several horizontal lines for text.

GHE

Blank writing area for the 'GHE' category, featuring a bench icon at the top and several horizontal lines for text.

GHI

Blank writing area for the 'GHI' category, featuring a pie icon at the top and several horizontal lines for text.

Nome _____ Classe _____ Data _____

CIA – CIO – CIU – GIA – GIO – GIU

  Leggi e copia al posto giusto.



Ciambella



Giornale



Faccia



Gioielli



Giudice



Valigia



Ciambolo



Calciatore



Ciotola



Fanciullo



Ciuccio



Ciliegia

CIA



Blank writing area for the word 'CIA'.

CIO



Blank writing area for the word 'CIO'.

CIU



Blank writing area for the word 'CIU'.

GIA



Blank writing area for the word 'GIA'.

GIO



Blank writing area for the word 'GIO'.

GIU



Blank writing area for the word 'GIU'.

Nome _____ Classe _____ Data _____

IL SUONO QU

 Forma le sillabe.

QU

A	E	I	O
↓	↓	↓	↓
QUA	_____	_____	_____
qua	_____	_____	_____
_____	_____	_____	_____
qua	_____	_____	_____

 Completa inserendo **QUA - QUE - QUI - QUO**.

 _____DERNO _____derno	 A _____LONE A _____lone	 LI _____RE Li _____re
 _____STURA _____stura	 LI _____RIZIA Li _____rizia	 _____DRIFOGLIO _____drifoglio

 Componi le parole e collegale al disegno.

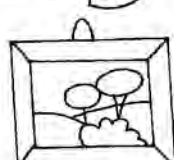
5	que - cin	_____
4	dro - qua	_____
	quin - di - ci	_____
15	qui - a - la	_____
	tro - quat	_____

  Leggi e disegna.

NELLO ZAINO CI SONO
QUATTRO QUADERNI
A QUADRETTI



Nome _____ Classe _____ Data _____

IL SUONO GN

 **Forma le sillabe.**





GN

A	E	I	O	U
↓	↓	↓	↓	↓
GNA	_____	_____	_____	_____
gna	_____	_____	_____	_____
_____	_____	_____	_____	_____
<i>gna</i>	_____	_____	_____	_____

 **Completa inserendo GNA - GNE - GNI - GNO - GNU.**

 LAVA _____ <i>Lava</i>	 RA _____ TELA <i>Ra tela</i>	 CASTA _____ <i>Casta</i>
 _____ _____	 CI _____ <i>ci</i>	 LE _____ <i>Le</i>

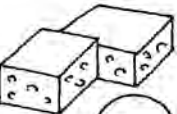
 **Componi le parole e collegale al disegno.**

	gni - ra	_____
	mon - gna - ta	_____
	mo - gno	_____
	gno - pu	_____
	gne - spu	_____

 **Osserva il disegno e completa la frase.**



LO _____
E IL _____
FANNO IL _____

Nome _____ Classe _____ Data _____

IL SUONO GLI

 Inserisci **GLI**.

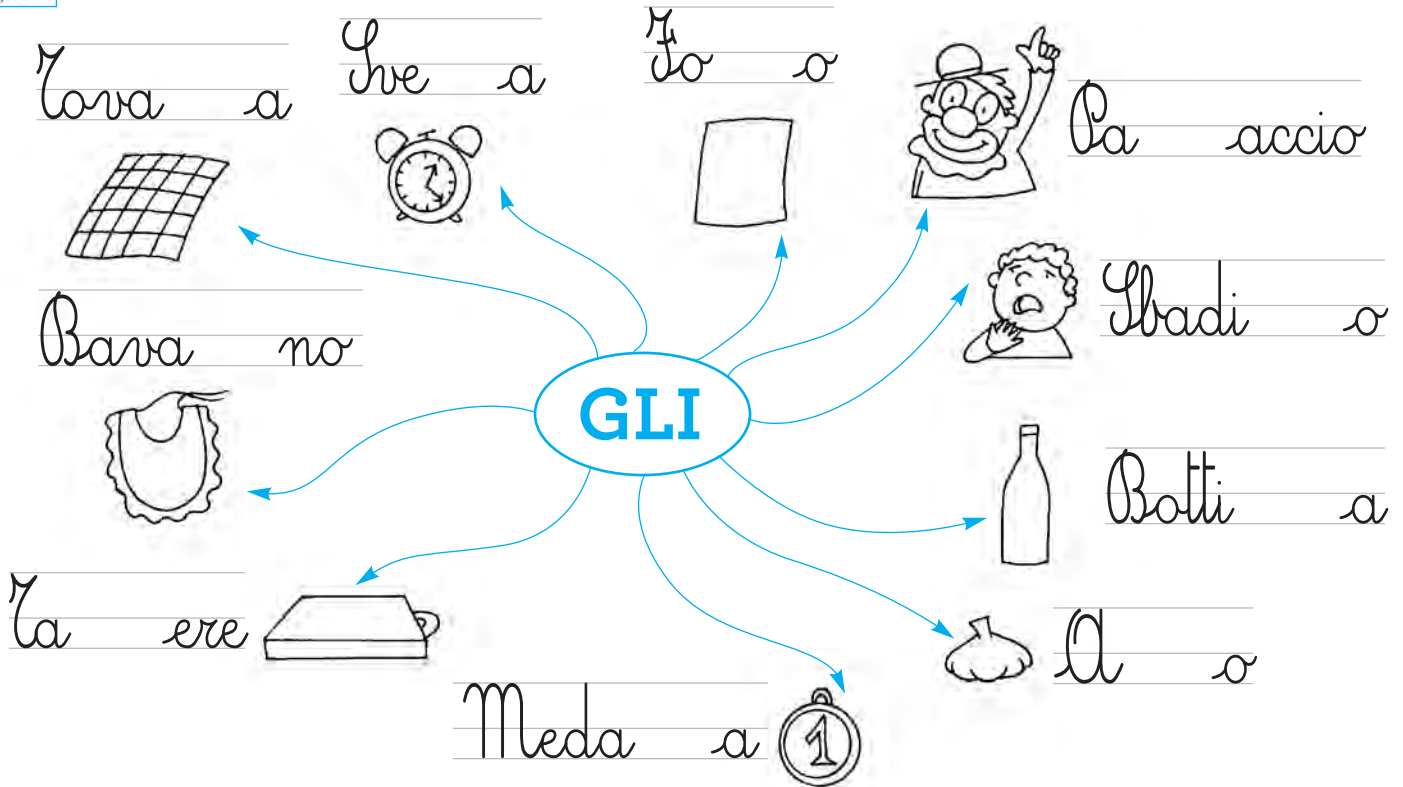

 Scrivi la parola.



IL _____

Il _____



LA _____

La _____



LA _____

La _____



IL _____

Il _____

  Leggi e disegna.

SULLA TOVAGLIA
 CI SONO DUE BOTTIGLIE



Nome _____ Classe _____ Data _____

I SUONI SCE – SCI

 Inserisci SCE o SCI.





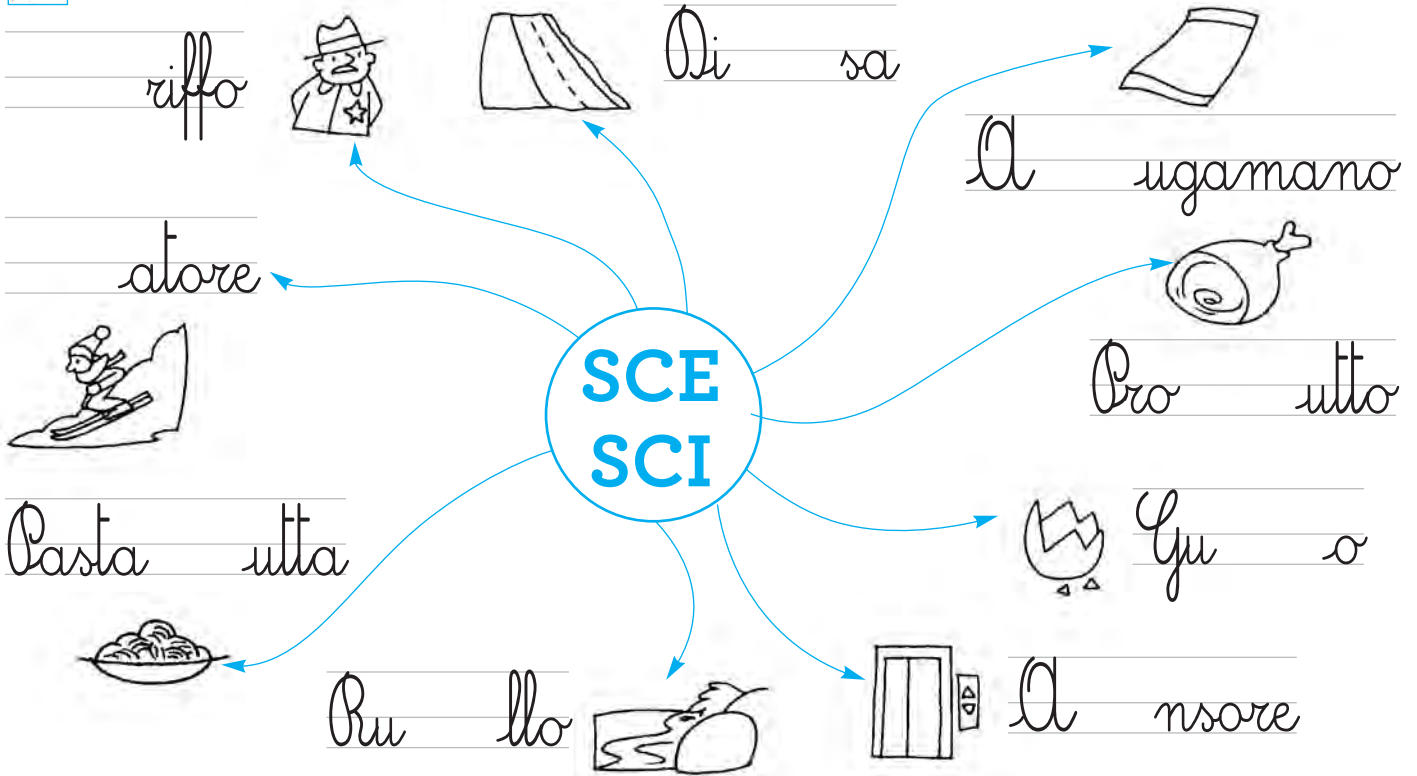

Diagram illustrating words with the sounds SCE and SCI. A central circle contains the words SCE and SCI. Lines connect this circle to various words and illustrations:

- Di _____ sa
- La _____ ugamano
- Pro _____ utto
- Gu _____ o
- La _____ nsore
- Ru _____ llo
- Pasta _____ utta
- at _____ ore
- Di _____ sa
- riffo _____



 Scrivi la parola.

Exercise for writing words starting with SCE or SCI. Each illustration is followed by a blank line and a cursive letter for tracing:

-  IL _____ *Il*
-  LA _____ *La*
-  GLI _____ *Gli*
-  LO _____ *Lo*
-  LA _____ *La*
-  LA _____ *La*

 Osserva il disegno e completa la frase.

LA _____ SCIVOLA
NEL _____



Nome _____ Classe _____ Data _____

I SUONI QU – GN – GLI – SC

  Leggi e copia al posto giusto.



Pugna



Fascia



Stagno



Castagna



Scoglio



Conchiglia



Sciatore

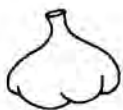

Aglio



Camoscio

15

Quindici



Squalo



Quadrifoglio

QU

Handwriting practice area for the sound QU, featuring a decorative scroll border and several horizontal lines for writing.

GN

Handwriting practice area for the sound GN, featuring a decorative scroll border and several horizontal lines for writing.

GLI

Handwriting practice area for the sound GLI, featuring a decorative scroll border and several horizontal lines for writing.

SC

Handwriting practice area for the sound SC, featuring a decorative scroll border and several horizontal lines for writing.

Nome _____ Classe _____ Data _____

L'USO DELL'H

 Leggi.



 Inserisci **HO** – **HA** – **HAI** – **HANNO**.



Io _____ un cappello

Fatima _____ la sciarpa.



Tu _____ i guanti.

Samir e Sayo _____ gli stivali.



Nome _____ Classe _____ Data _____

LE DOPPIE

 Togli una consonante e riscrivi.

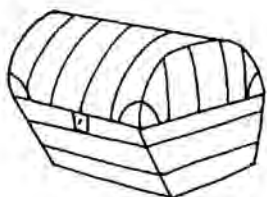

C A S S A

□ □ □ □

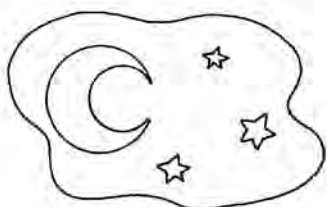

N O T T E

□ □ □ □

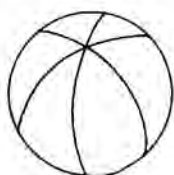
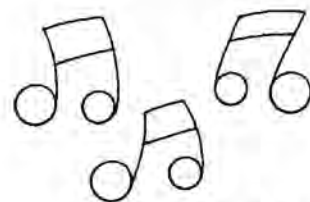

P A L L A

□ □ □ □

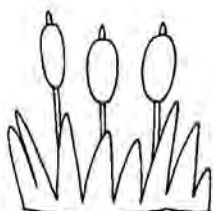
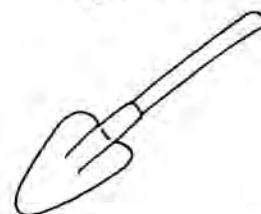

C A N N E

□ □ □ □

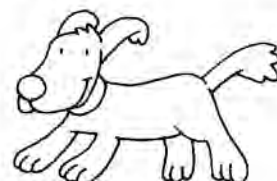

S E T T E

□ □ □ □

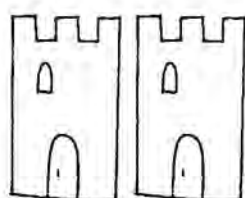

T O R R I

□ □ □ □

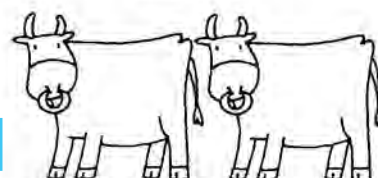

  Leggi e cerchia le parole con lettere doppie.



STELLA

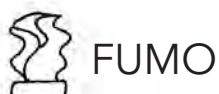

FUMO



BAFFI



PENNA



BANCO



TAZZA



PIAZZA



CAPELLI

Nome _____ Classe _____ Data _____

LE DOPPIE



Colora solo i disegni che hanno un nome con le doppie.



Scrivi i nomi con le doppie.

Nome _____ Classe _____ Data _____

A SCUOLA



Leggi, collega le frasi ai disegni, poi copiale.

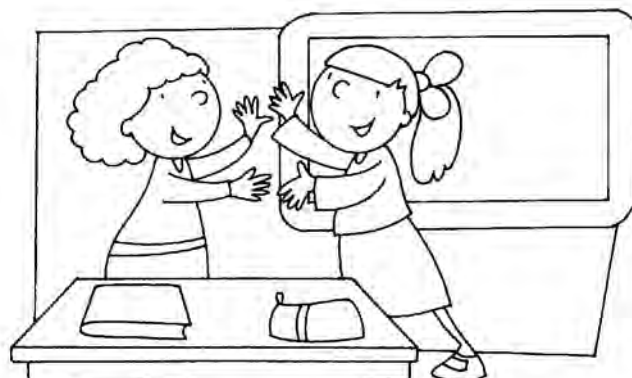
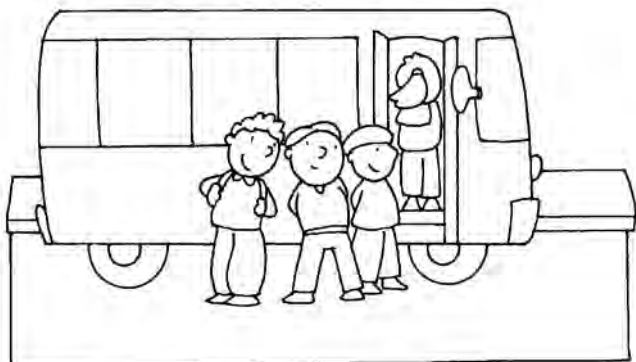

I BAMBINI GIOCANO IN CORTILE.

I BAMBINI LAVORANO IN CLASSE.

I BAMBINI VANNO IN GITA.

LE BAMBINE GIOCANO IN CLASSE.

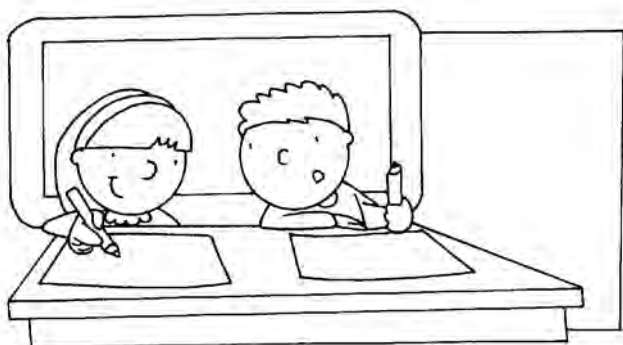

Nome _____ Classe _____ Data _____

IN CORTILE



Leggi, collega le frasi ai disegni, poi copia.

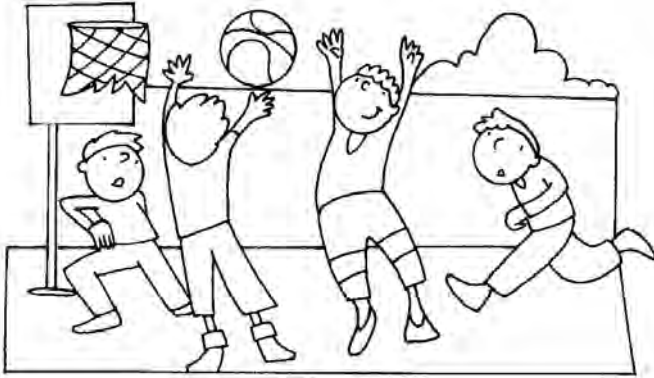

DUE BAMBINI GIOCANO CON LE FIGURINE.

LE BAMBINE GIOCANO CON I PUPAZZI.

SHILA E MARTA SONO SEDUTE SULLA PANCHINA.

QUATTRO BAMBINI GIOCANO A BASKET.



Nome _____ Classe _____ Data _____

A CASA



Leggi, collega le frasi ai disegni, poi copia.

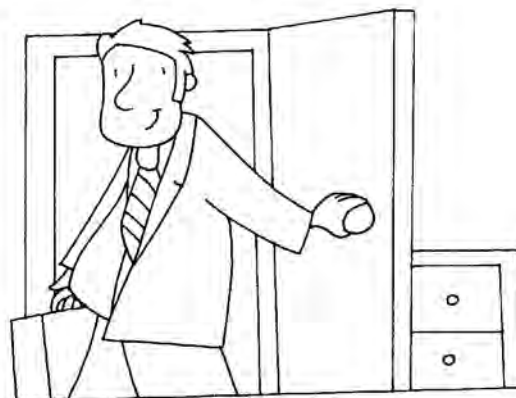
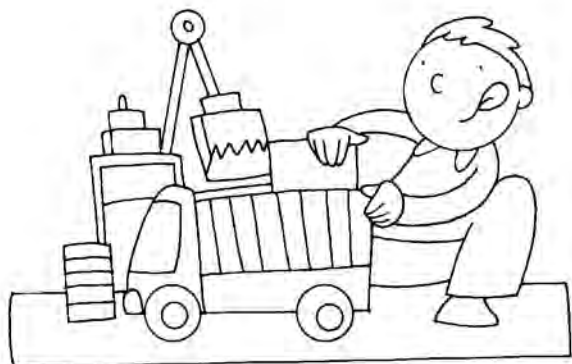

IRINA GUARDA LA TELEVISIONE.

LA MAMMA PREPARA LA COLAZIONE.

IL PAPÀ CHIUDE LA PORTA.



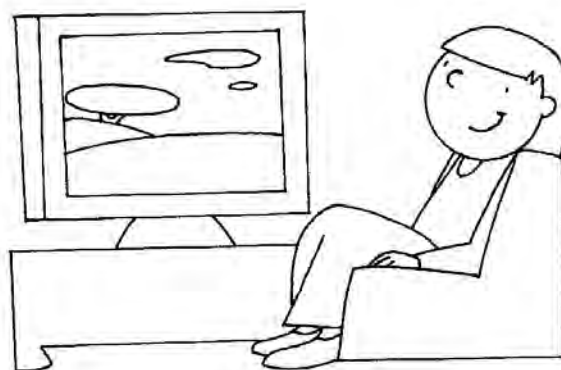



IL FRATELLO DI IRINA GIOCA.



Nome _____ Classe _____ Data _____







VERIFICA

  Inserisci in ogni casella una lettera, poi leggi nelle caselle evidenziate.

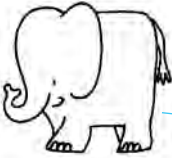
■				■				■	■	■
■				■			■	■	■	■
■	■	■		■						
				■	■	■	■	■	■	■
■				■			■	■	■	■
■	■	■		■					■	■

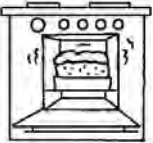
  Inserisci in ogni casella una sillaba, poi leggi nelle caselle evidenziate.

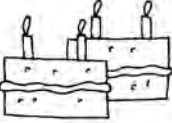
■	■				
	■			■	■
■	■		■	■	■
	■	■	■	■	■

■		■	
		■	■
■		■	■
		■	■

MI AUTOVALUTO

Queste attività sono state: **facili**  **abbastanza**  **difficili** 

A	E	I	O	U
BA	BE	BI	BO	BU
CA	CHE	CHI	CO	CU
CIA	CE	CI	CIO	CIU
DA	DE	DI	DO	DU
FA	FE	FI	FO	FU
GA	GHE	GHI	GO	GU
GIA	GE	GI	GIO	GIU
LA	LE	LI	LO	LU
MA	ME	MI	MO	MU

NA

NE

NI

NO

NU

PA

PE

PI

PO

PU

RA

RE

RI

RO

RU

SA

SE

SI

SO

SU

TA

TE

TI

TO

TU

VA

VE

VI

VO

VU

ZA

ZE

ZI

ZO

ZU

GNA

GNE

GNI

GNO

GNU

QUA

QUE

QUI

QUO

SCI

SCE

GLI

Griglia per la rilevazione del raggiungimento degli obiettivi

Obiettivo	Sì	No	In parte
Si relaziona positivamente con i compagni.			
Si relaziona positivamente con gli adulti.			
Comprende semplici consegne.			
Risponde a semplici domande a risposta chiusa.			
Si esprime utilizzando la parola-frase.			
Si esprime utilizzando frasi semplici, ma corrette.			
Chiede aiuto se non capisce.			
Usa codici non linguistici per comunicare.			
Comprende il significato delle principali parole di uso quotidiano.			
Pronuncia correttamente le principali parole di uso quotidiano.			
Copia autonomamente semplici parole.			
Riconosce in modo globale alcune parole che vede scritte.			
Distingue le lettere dell'alfabeto.			
Sa formare le sillabe.			
Legge le sillabe.			
Usa le sillabe per formare parole bisillabe piane.			
Usa le sillabe per formare parole complesse.			
Sa scrivere sotto dettatura semplici parole.			
Sa scrivere sotto dettatura semplici frasi.			
Sa leggere autonomamente semplici parole.			
Sa leggere autonomamente semplici frasi.			
Sa scrivere autonomamente semplici parole.			
Sa scrivere autonomamente semplici frasi.			

Nome alunno: _____

Classe: _____

Data: _____

INDICE

Introduzione

Il bambino straniero in classe	2
Risorsa o problema?	2
Integrazione o cancellazione di identità?	2
Come procedere?	2
L'apprendimento della lingua	2
L'apprendimento della letto-scrittura	3
Verso l'autonomia	3
Osservare e valutare	3
La normativa	4
Programmazione	5
Griglia di osservazione iniziale	6
 <i>Ipotesi di lavoro per l'insegnante – L'accoglienza</i>	7
La filastrocca del paese	8
Accoglienza – Schede operative	9
 <i>Ipotesi di lavoro per l'insegnante – Le parole</i>	31
Le parole – Schede operative	32
Verifica	68
 <i>Ipotesi di lavoro per l'insegnante – Leggere e scrivere</i>	69
Leggere e scrivere – Schede operative	70
Verifica	90
Leggere e scrivere – Schede operative	91
Verifica	108
 Lettere e sillabe da ritagliare	109
 Griglia per la rilevazione del raggiungimento degli obiettivi	111

LE MONOGRAFIE SPIGA Italiano per stranieri 1° livello

Testi: Elena Costa, Lilli Doniselli, Alba Taino
Coordinamento redazionale: Mafalda Brancaccio
Progetto grafico: Sergio Elisei
Impaginazione: Esseci • Milano
Illustrazioni: Anikibobo • Torino
Copertina: Valentina Mazzarini

Stampa Tecnostampa • Recanati 10.83.141.0

Tutti i diritti riservati

© 2010 **ELI s.r.l. • LA SPIGA**

via Soperga, 2 – Milano

Tel. 02 2157240

info@laspigamodern.com

La casa editrice LA SPIGA e l'ambiente

La casa editrice LA SPIGA usa carta certificata FSC per tutte le sue pubblicazioni. È un'importante scelta etica, poiché vogliamo investire nel futuro di chi sceglie ed utilizza i nostri libri sia con la qualità dei nostri prodotti sia con l'attenzione all'ambiente che ci circonda. Un piccolo gesto che per noi ha un forte significato simbolico. Il marchio FSC certifica che la carta usata per la realizzazione dei volumi ha una provenienza controllata e che le foreste sono state sottratte alla distruzione e gestite in modo corretto.



Misto

Gruppo di prodotti provenienti da foreste correttamente gestite e da altre origini controllate

www.fsc.org Cert no. SQS-COC-100207

© 1996 Forest Stewardship Council